

en

On-roof and Flat-roof Supports for Intelli-heat PS2.4 Panels

Installation and Assembly Instructions for the **INSTALLER**

da

Montagesystem til solpanel Intelli-heat PS 2.4 for montage på tag med hældning eller fladt tag.

Installations- og montagevejledning for **installatøren**

sv

Monteringssystem ovan-tak och platt-tak för solfångare Intelli-heat PS 2.4

Installations och montagevägledning för **installatören**

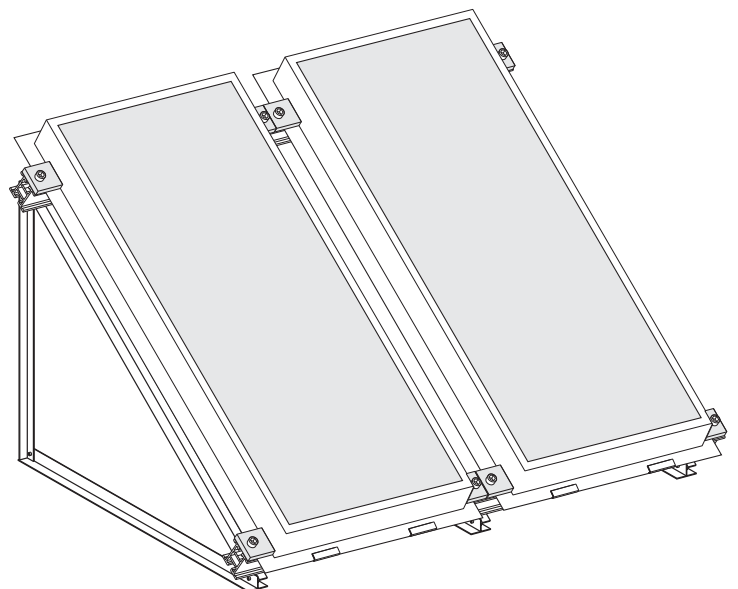
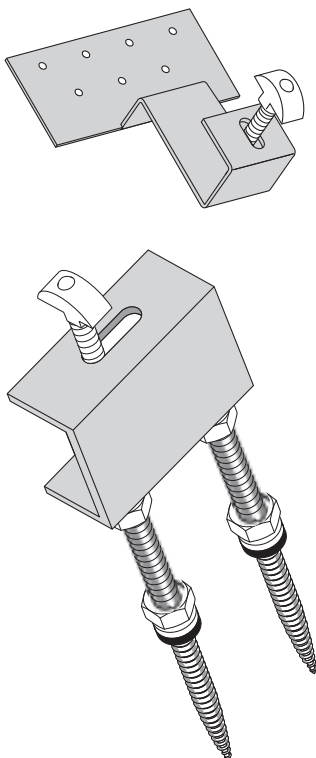



en Please note the following instructions regarding laws, regulations and technical rules.

When setting up solar energy installations, the laws and regulations at local, state, European and international level that apply to the country in question must be observed. Generally acknowledged technical regulations apply; these are usually formulated in the form of standards, guidelines, provisions, regulations and technical rules laid down by local and national bodies, energy supply companies, trade organisations and technical committees in the relevant fields. The installation of solar units may require improved rain resistance with regard to roof, wall and sealing technology and must be taken into account accordingly. To meet regulations for the prevention of accidents, it may be necessary to use safety equipment (straps, scaffolding, supports, etc.). Such safety equipment is not supplied and must be ordered separately. Installation must only be carried out by technically qualified and authorised personnel with a recognised qualification (verified by a state or national body) in the relevant technical area.

da Vær opmærksom på gældende lovgivning, regulativer og tekniske foreskrifter.

Når et solvarmeanlæg etableres skal gældende lovgivning og regulativer, det være sig nationalt som internationalt overholdes; normalt er dette formuleret i standarder, retningslinier, regulativer og tekniske foreskrifter udarbejdet af myndigheder, brancheorganisationer og tekniske komiteer inden for det relevante område. Ved installeringen af solvarme-panelet kan en forbedret beskyttelse mod regn, angående tagfladen, væg og mur samt tætningsmetoden være påkrævet, og dette skal der derfor tages højde for ved måden installationen udføres på. For at imødekomme regler og lovgivning vedrørende beskyttelse mod arbejds-ulykker, skal der anvendes sikkerheds-udstyr (stropper, stillads, understøtning mm.). Sikkerhedsudstyret medleveres ikke, men skal bestilles særskilt. Installationen må kun udføres af personer med fagligt relevante kvalifikationer og autorisationer.

sv Utöver innehållet i instruktionerna skall även uppmärksammas gällande lagregler och tekniska föreskrifter.

När en solfångaranläggning skall installeras kan det vara nödvändigt att söka bygglov. Närmare information om detta finns att ta del av hos Er kommun. Installation av solfångaranläggningen kan kräva ett förbättrat skydd mot regn avseende tak, väggar etc beroende på hur installationen utförs. För att följa lagar och regler vidrörande skydd mot arbetsolyckor är det nödvändigt att i förekommande fall använda säkerhetsutrustning (säkerhetslina, byggnadsställning, understöd mm). Denna utrustning medföljer inte vid leverans utan måste beställas separat. Installationen ska bara utföras av auktoriserade personer med relevanta tekniska kunskaper.

en NOTE: The hanger-bolt mounting system, described in this manual, is visualized exemplary!



da OBS: De i manualen beskrevne monteringsbeslag og bolte, er kun visuelle eksempler!

sv OBS! De i manualen beskrivna monteringsbeslag och bultar är endast visuella exempel!

en Installation/Operating Manual, Art. No. 255 195, 09.2007. We reserve the right to make changes.

da Installations- og monteringsmanual Art. 255 195, 09.2007. Ret til ændringer forbeholdes.

sv Installations och monterings manual Art. 255 195, 09.2007. Vi förbehåller oss rätten till konstruktionsändringar och reserverar oss mot eventuella tryckfel.

					
4	en da sv	Explanation of pictograms used Forklaring til anvendte symboler Forklaring till använda symboler	32	en da sv	Hydraulic installation Hydraulisk instruktion Inst. av röranslutningar
5	en da sv	Product description Produktbeskrivelse Produktbeskrivning	33	en da sv	Installation of hydraulic fixed bearing and end plug Inst. fittings og slutmuffe Inst. kopplingar och ändproppar
6	en da sv	General warnings Generelle advarsler Generella varningar	34	en da sv	Note: Position of the on-roof breather Bemærk: Position af udlufter på taget OBS!: Placering av utluftning på taket
7-8	en da sv	Scope of supply/Ascertainment of need Leveringsomfang Leveransomfattning	35	en da sv	Installation of temperature sensor Inst. af temperaturføler Placering av temperaturgivare
9	en da sv	Determination of requirements Bestemmelse af levering Behovsanpassade delar	36	en da sv	roof penetration Gennemføring i tag Takgenomföring
10	en da sv	Also required Andre dele påkrævet Övriga nödvändiga delar	37	en da sv	Technical data Tekniske data Tekniska data
12	en da sv	Overview: Installation system, horizontal Oversigt: system installaret (vandret) Översikt: system horisontelt			
13	en da sv	Dimensions and fixing distances, horizontal Dimensioner og fikseringsmål Dimensioner och fixeringsmått			
14-15	en da sv	Mounting steps for hanger bolt installation Monterings trin m. støttebolt beslag Inst. av fästfuncter med takbult			
16-17	en da sv	Installation of fixing points, rafter independently Inst. af fikseringspunkter uafh. af spær Inst. av fästpunkter på tegellåkt			
18	en da sv	Installation of fixing points, rafter dependently Inst. af fikseringspunkter afhængig af spær Inst. av fästpunkter på takstol			
19	en da sv	Installation of horizontal mounting rail Instruktion af vandrette mont. skinner Inst. av horisontell montageskena			
20	en da sv	Overview: Flat-roof installation system Oversigt: inst. fladt tag Översikt: system, platt tak			
21	en da sv	Dimensions and fixing distances, flat-roof Dimensioner og fikseringsmål til fladt tag Dimensioner och fixeringsmått			
22	en da sv	Note: Flat-roof installation system NB. Inst system fladt tag Viktigt! Installation på platt tak			
23-25	en da sv	Flat roof installation: flat-roof brackets Inst. fladt tag: Stativ fladt tag Inst. av stativ på platt tak			
26-29	en da sv	Collector installation: horizontal base rails Inst. af solpanel: vandrette skinner Inst av solfångare på montageskena			
30	en da sv	Installation of the Enhancement kit Inst. af udvidelsesmodul Inst. av kompletteringsmodul			
31	en da sv	Installation of expansion bend - Position of the on-roof breather Inst. af kompensator Inst. av kompensator			

Explanation of pictograms used



en Warning, danger to environment and products
da Advarsel, fare for hhv. omgivelser og produkt
sv Varning! fara för omgivning och produkt



en consider importantly
da Vigtigt
sv Viktigt



en Warning! Danger of scalding
da Advarsel! Fare for skoldning
sv Varning! Fara för brännskada



en hand tight
da Spændes til med hånden
sv Spänn fast för hand



en tighten firmly
da Spændes sikkert til
sv Spänn fast med verktyg



en advice, information
da Information, vejledning
sv Information, vägledning



en dimension
da Dimension
sv Dimension



en see page
da Se side
sv Se sida



en Basic kit 1
da Basis sæt 1
sv Bas modul 1



en Enhancement kit
da Udvidelsesmodul
sv Kompletteringsmodul



en Accessory kit (vertical)
da Tilbehørs-sæt (lodret)
sv Tillbehörsset (vertikal)



en Materials to be provided
da Materiale der skal anskaffes
sv Material som skall anskaffas



en Technical data
da Tekniske data
sv Tekniska data



en orthogonal
da Retvinklet
sv Rät vinkel



en Installation kits have been designed as a fixing system for solar units and must only be used in accordance with their stated structural capability. They are designed for roofs with inclines from 22° to 65°. Installation on roofs with shallow pitch requires a special installation kit. The dimensions and data specified can vary depending on the solar unit selected, therefore on-site checking is required. Inappropriate use of the design and changes that are not permitted for the installation will invalidate all liability claims.

da Montagen er designet som et fastgjort solpanel-system og må kun anvendes i overensstemmelse med disse betingelser. Solpanelets montagesystem er designet til tag med en hældning på 22° til 65°. Installation på tag med lav rejstning kræver et specielt montagesæt. Dimensioner, mål og de specifikke data kan variere afhængig af det valgte solpanels montagesystem. Derfor bør der altid foretages en kontrolmåling på installationens placering. Uautoriseret brug af systemets design samt ikke godkendte ændringer på udstyret og systemet kan medføre, at al garanti bortfalder.



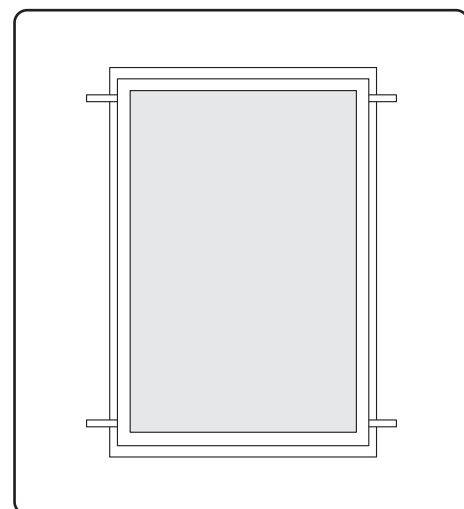
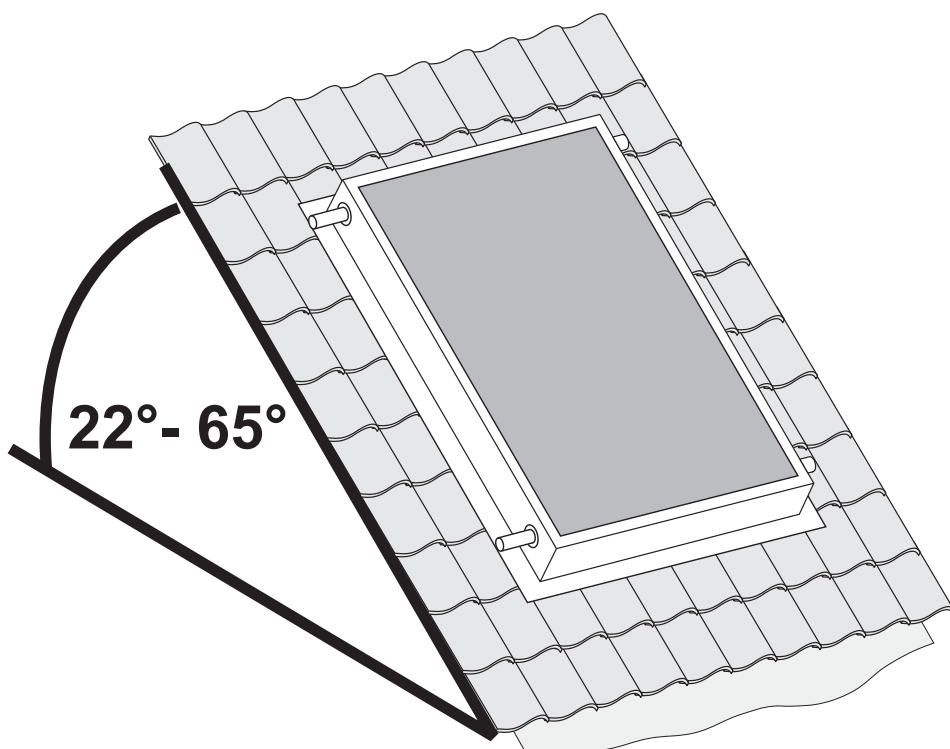





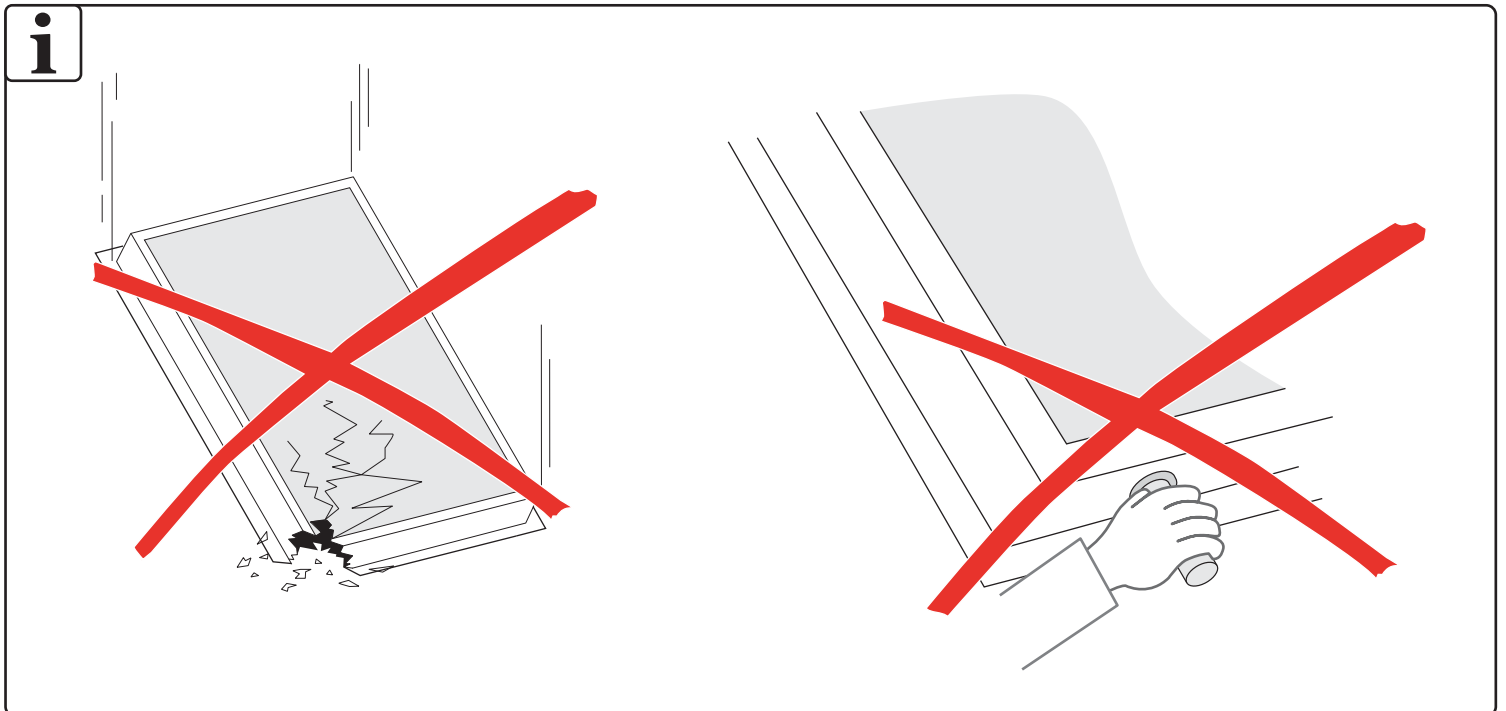
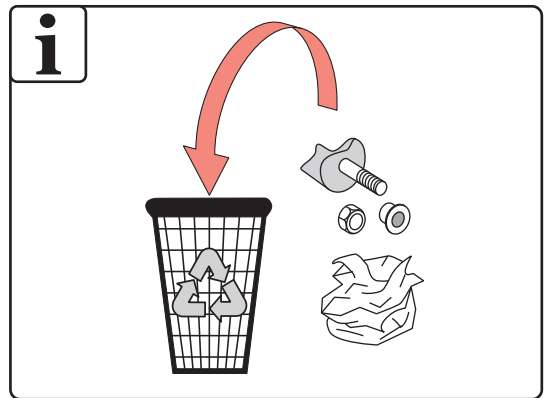
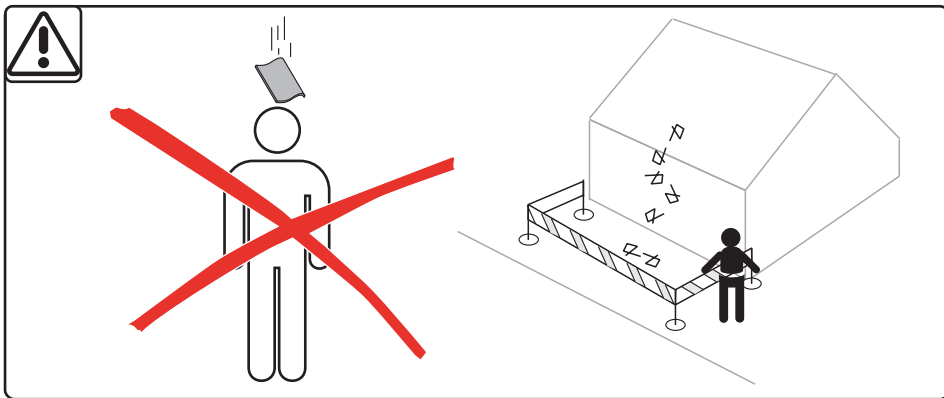
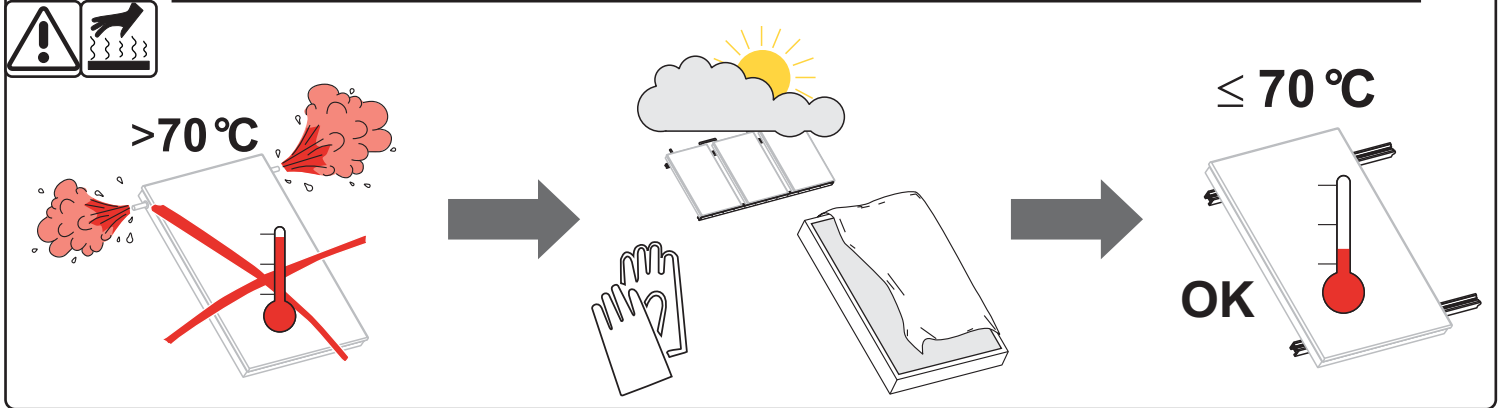
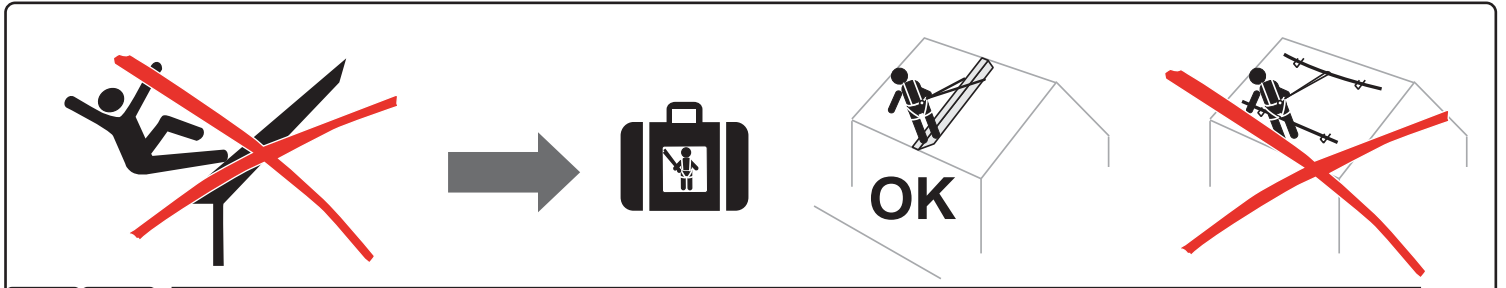



sv Montagesystemet är designat för att vara förankrat och solfångarsystemet får endast användas till detta ändamål. Montagesystemet är designat för en lutning på 22° till 65°. Installation på tak med liten lutning kräver ett speciellt montageset. Dimensioner, mått och data kan variera beroende av den valda solfångarens montagesystem. Därför bör en kontrollmåling ske av installationens placering. Otillbörlig användning av systemets design samt inte godkända ändringar kan medföra att garantin slutar att gälla.



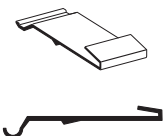
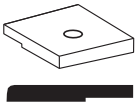
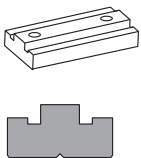

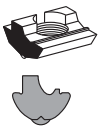







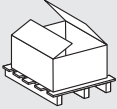



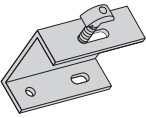
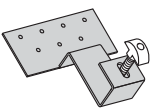

General Warnings



							
en Mounting rail da Monteringsskinne sv Montageskena		2		2	2		2
en Mounting hook da Monteringskrog sv Monteringskrok		4		4	2		2
en Retaining clip da Holdeclips sv Fasthållningsbeslag		8		8	4		4
en Coupling kit (including fixing) da Sammenbygningssæt sv Kopplingsbeslag		-		-	2		2
en Hexagon socket head screw (M8x16) da Unbraco universal skrue (M8x16) sv Insex skruv (M8x16)		8		8	-		-
en Hexagon socket head screw (M8x20) da Unbraco universal skrue (M8x20) sv Insex skruv (M8x20)		-		9	-		3
en Anchor block da Ankerblok sv Ankarbeslag		8		8	4		4
en installation instruction da Installationsvejledning sv Installationsvägledning		1		1	-		-
en Punching screw (cheese head, M8) da Gevind-borende skrue (M8) sv Skruv med glidskydd (M8)		-		-	4		4
en Flat roof angle bracket da Stativ/konsol til fladt tag sv Stativ för platt tak		-		3	-		1

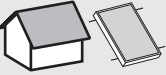
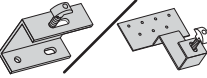

						
en Hanger bolt M10 da Støttebolt M10 sv Takbult +	12		-	4		-
en Double adapter, washer + nut da Bøjle, Spændeskive + Møtrik sv Bygel, Låsbricka + Mutter 	6		-	2		-
en or Roof anchor, washer + nut da og Taganker, Spændeskive + Møtrik sv och Takankare, Låsbricka + Mutter 	6		-	2		-

				
	1	1	1/2	1/2
	-	1	2/0	3/1
				
	≥ 6	≥ 8	≥ 10	≥ 12
				
	3	4	5	6



Also required



en Antifall guard
da Sikkerhedsudstyr
sv Säkerhetsutrustning



en Heat transfer liquid
da Frostbeskyttelsesvæske for solpanel
sv Frysskyddsvätska

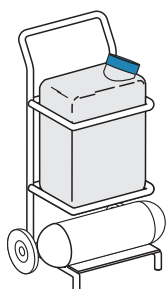

en Filling station
da Fyldestation
sv Påfyllningsstation



en Thermal conducting paste
da Termopasta
sv Kontaktpasta



en Temperature sensor
da Temperaturføler
sv Temperaturgivare



en Sealing plug
da Endeprop
sv Ändpropp



en Expansion bend
da Kompensator
sv Kompensator



en Copper pipe 18x1 mm
da Kobberrør
sv Kopparrör 18x1 mm



en Solar hand breather
da Manuel solar-udlufter
sv Manuell avluftare

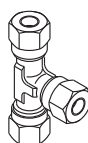

en T-Connection (temperature stability to 160°C)
da Tee-rør
sv Klämringskoppling, T-rör

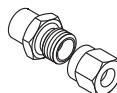

en Simple pipe connector
Clamping ring connector; internal thread 18 mm x 3/8"
da Overgang (rørfittings) Klemmerings forbindelse: rørgvind; Ø18mm x 3/8"
sv Klämringskoppling, rak inv. övergång, 18xR10



en hydraulic fixed bearing
da Hydraulisk fikseringsholder
sv Rördists

en suitable sealing material for the pressure tight execution of pipe connections (hemp, Loctite, or similarly)
da Et passende pakningsmateriale for klemmerings-fittings til rørforbindelserne (fx Hemo, Loctite)
sv Passande tätnings material för gängade anslutningar (lin, Loctite eller liknande).

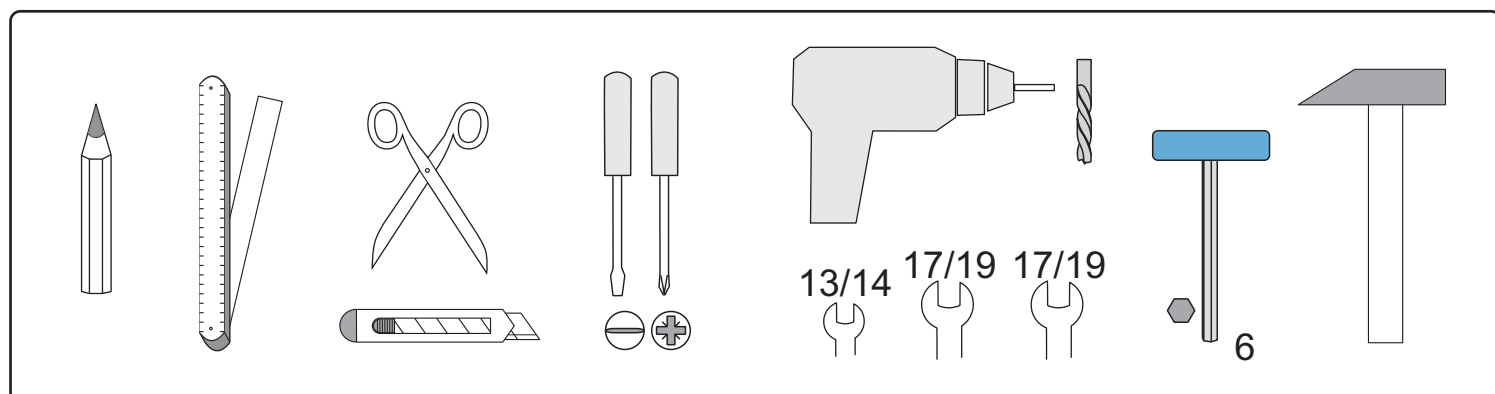

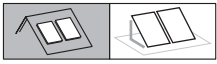

- en The solar unit used in these assembly and operating instructions is only given as an example. The dimensions and data given here must be tailored, if necessary, to individual requirements.
- da Solpanelerne som er samlet og monteret i denne instruktion, er kun vist som eksempler. De dimensioner og data der er opgivet, skal eventuelt kunne tilpasses individuelle løsninger og krav.
- sv Solfångarna som installeras i denna installationsvägledning visas endast som exempel. De dimensioner och data som uppges kan eventuellt behövas anpassas till individuella lösningar och krav.

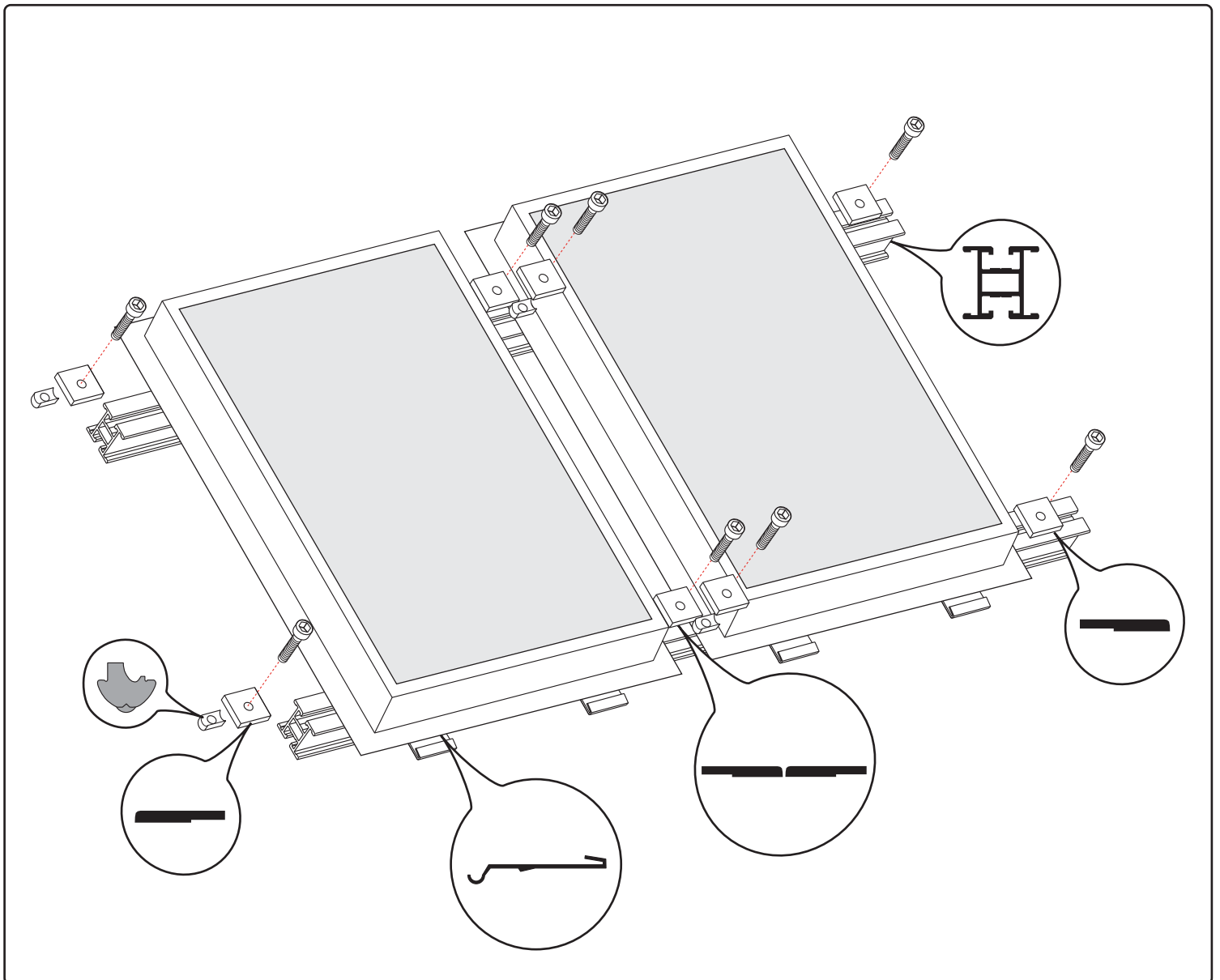



$a = 1204 \pm 100$
 $b = 2104$

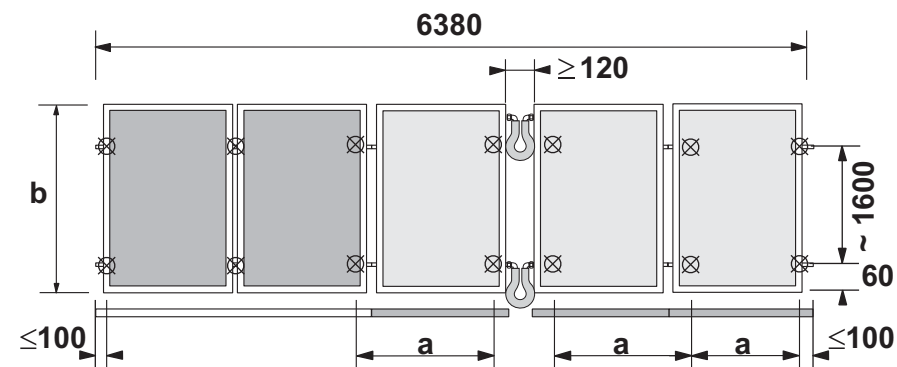
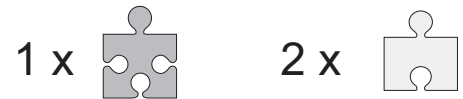
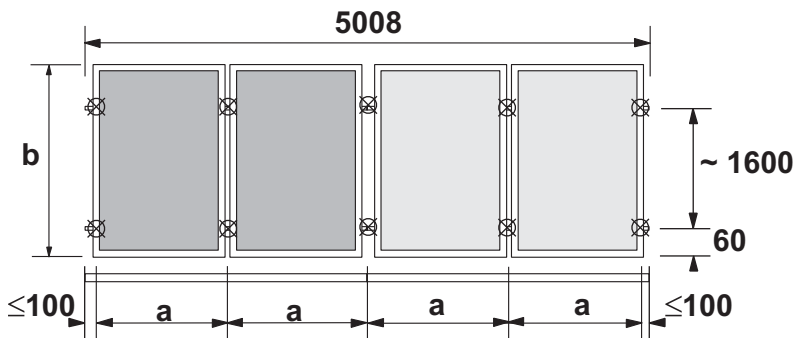
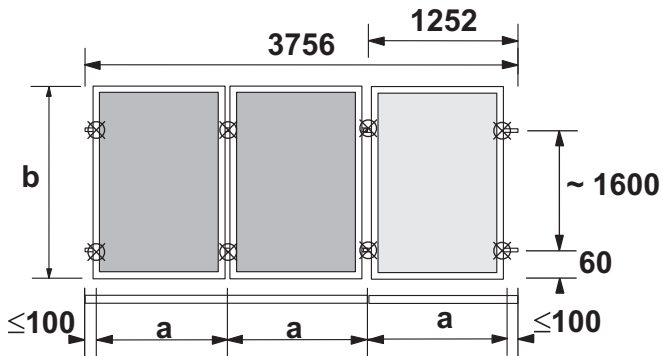
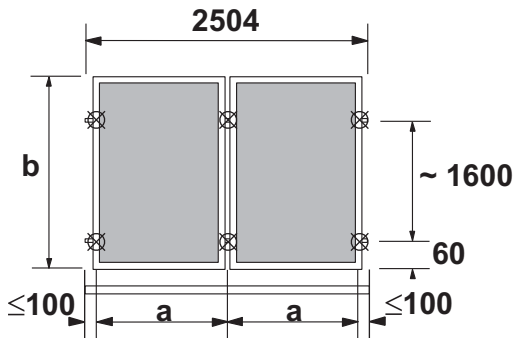

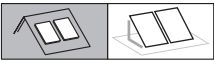

1

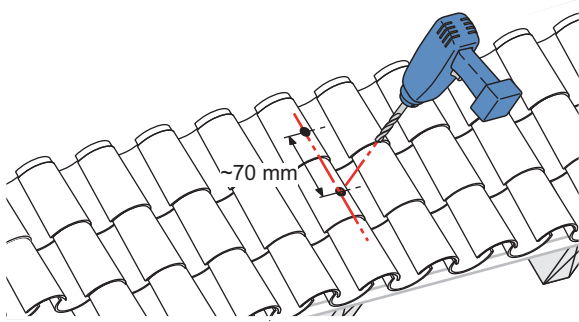

en Hanger Bolt Components
da Støttebolt
sv Takbult

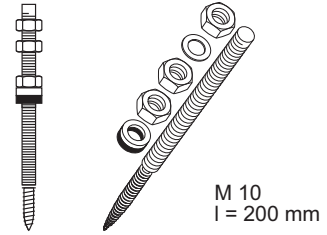

en Additional Component :
Hanger bolt adapter
da Andre dele:
Støttebolt-beslag
sv Takbults beslag

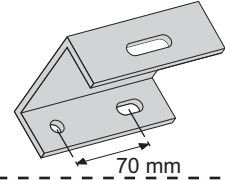

en M10 Bit
for screwing tie
screw into the roof
da M10 bit: Til at skrue fastgørelses-
skruen i taget
sv M10 bits: För fastdragnig av takbult

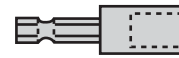

2

en use M10-Bit to fasten the bolt
da Anvend M10 Bit til at fastspænde boltten
sv Använd M10 biten för att dra fast takbulten

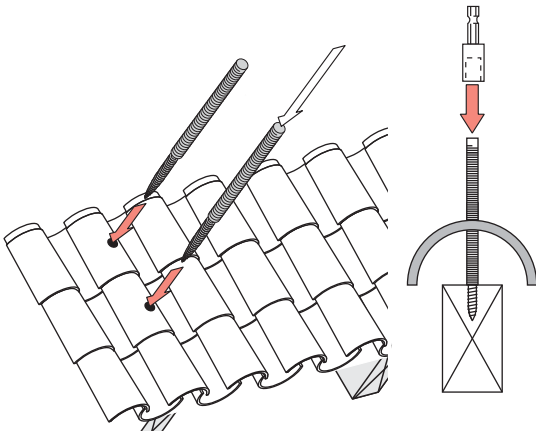

3

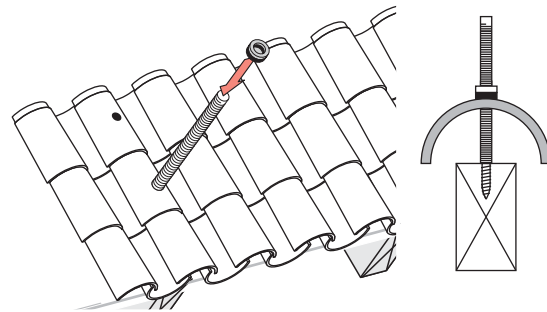

4

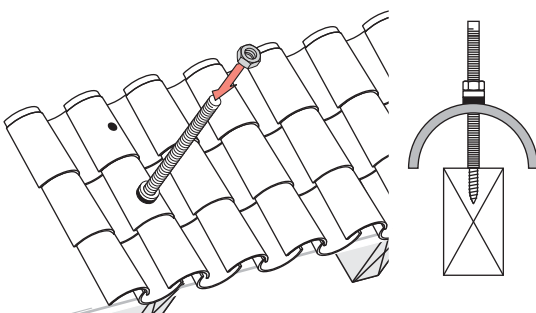

5

en permissible deformation of the gasket max.10%
da Max. tilladelige deformation af pakning: 10%
sv Max tillåten kompression av packning är 10%

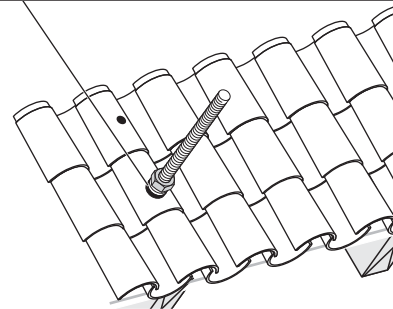

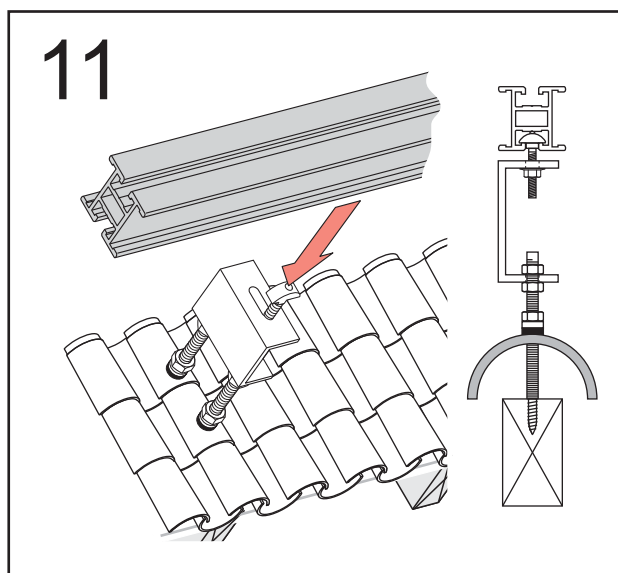
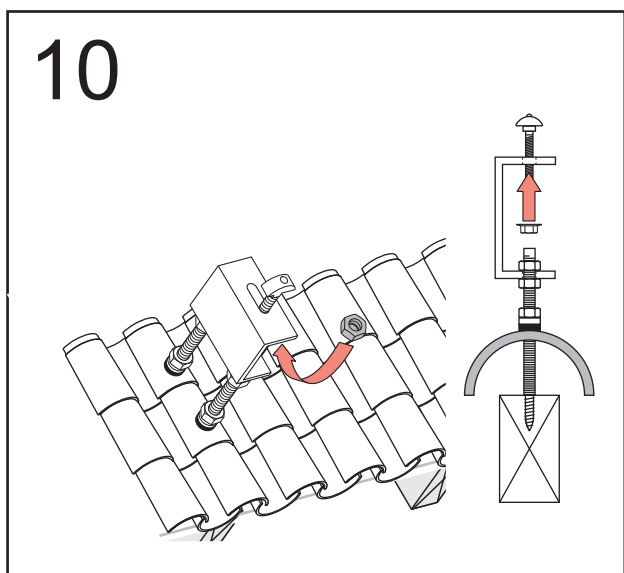
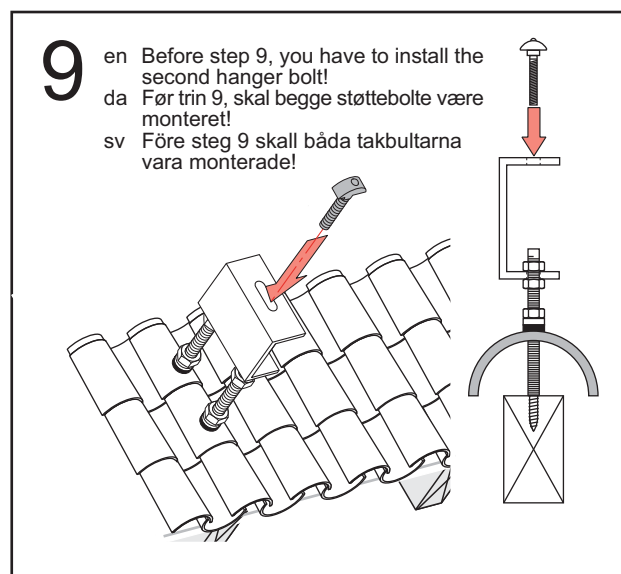
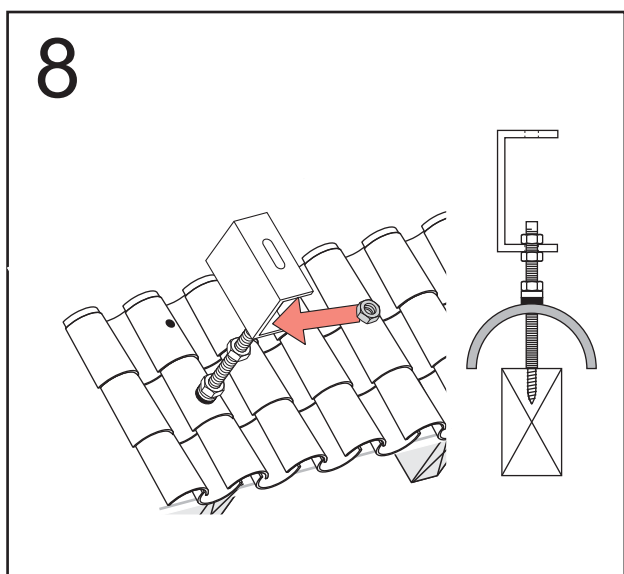
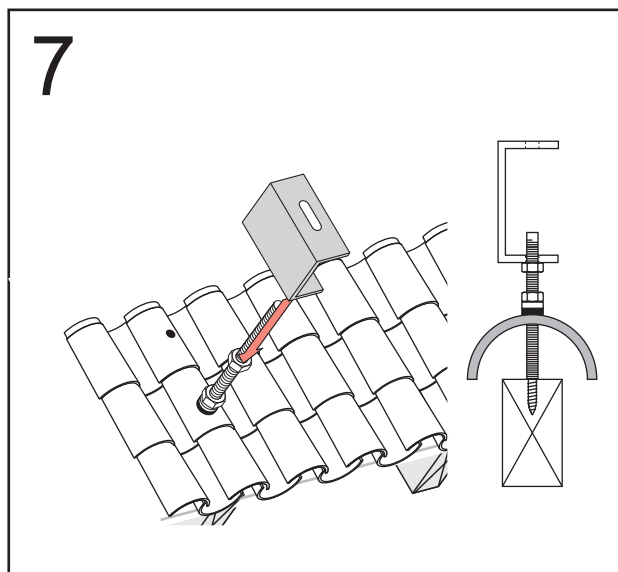
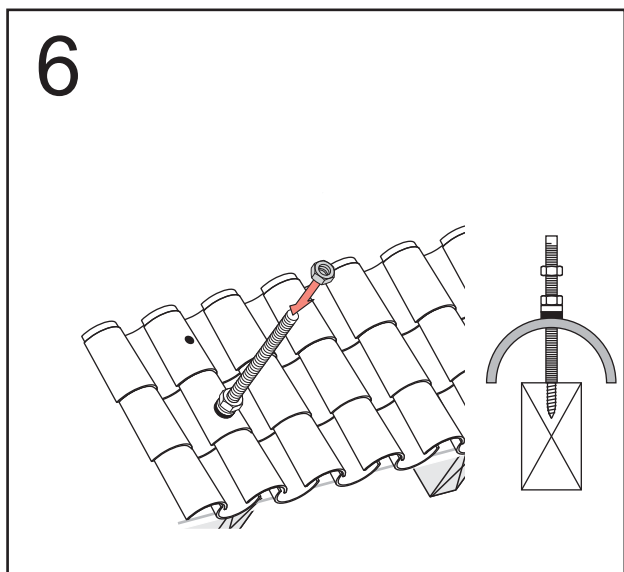

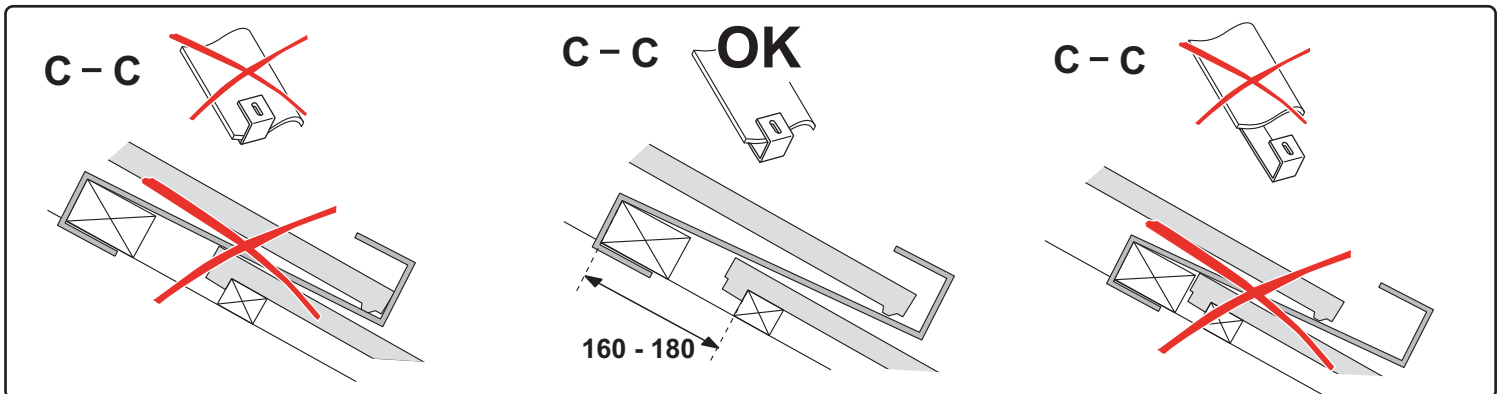
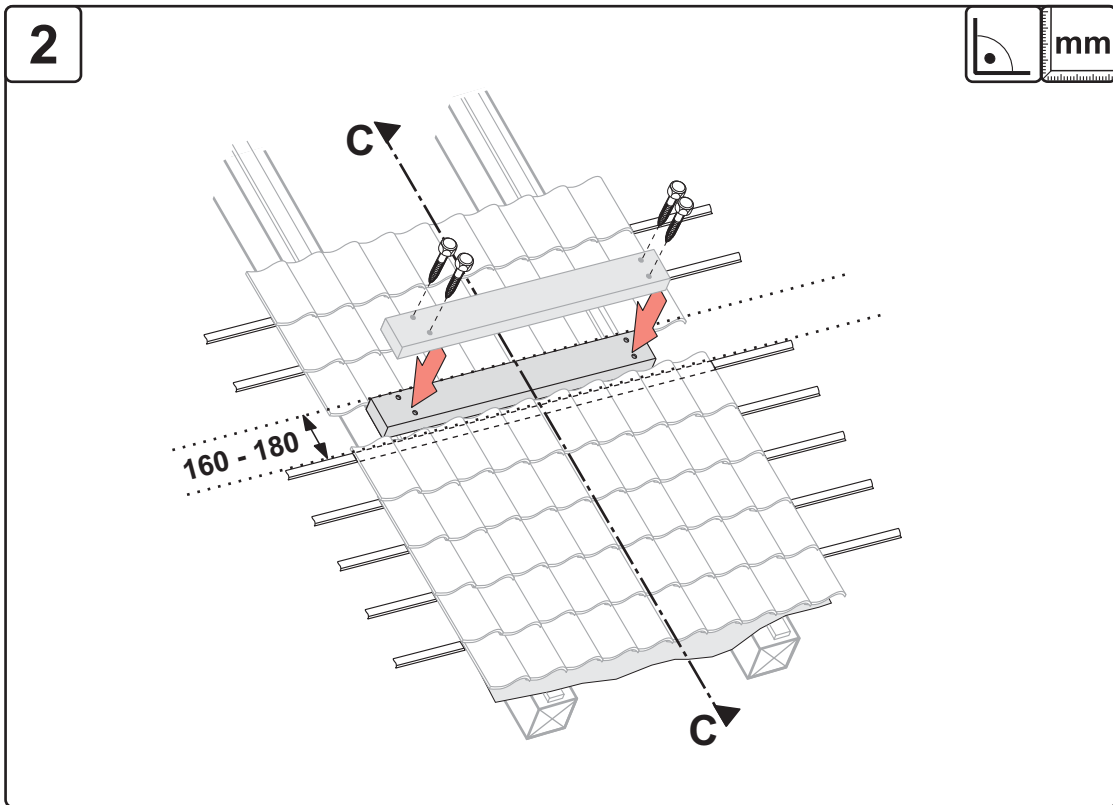
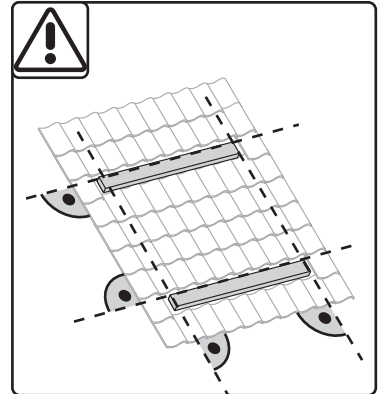
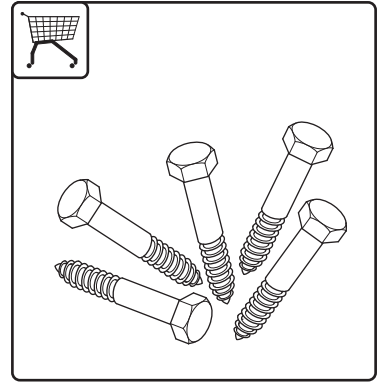
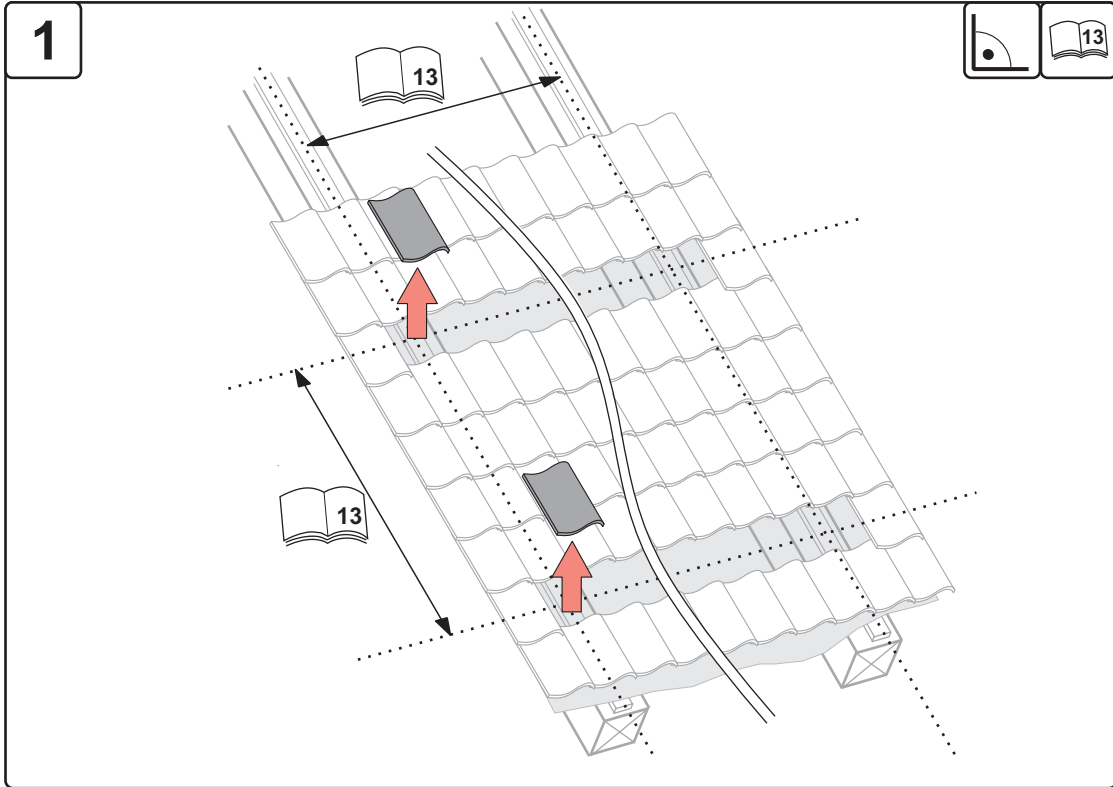
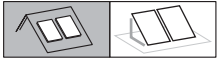
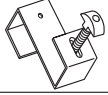

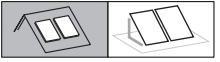

3

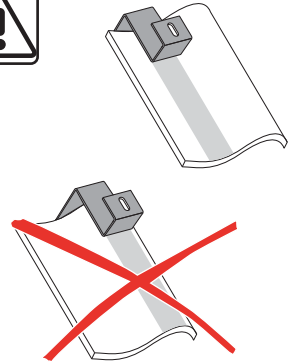
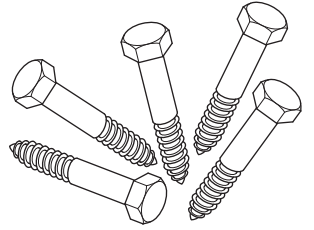
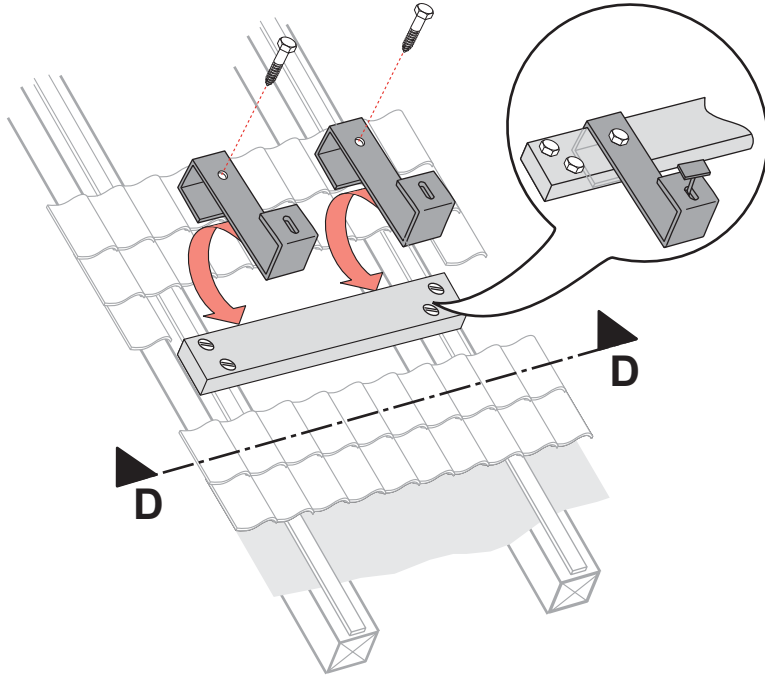

D - D

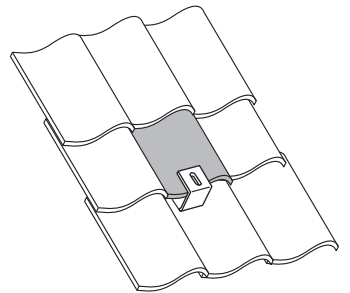
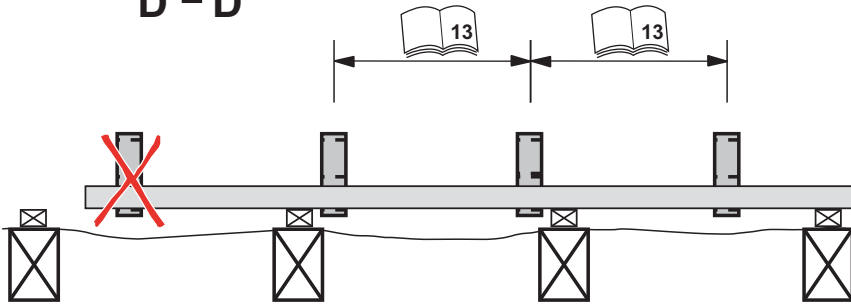

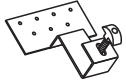

1

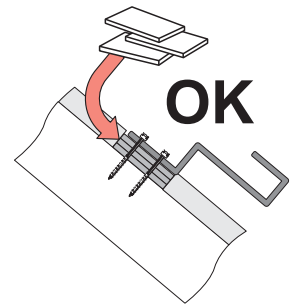
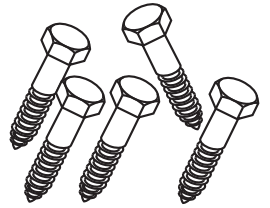
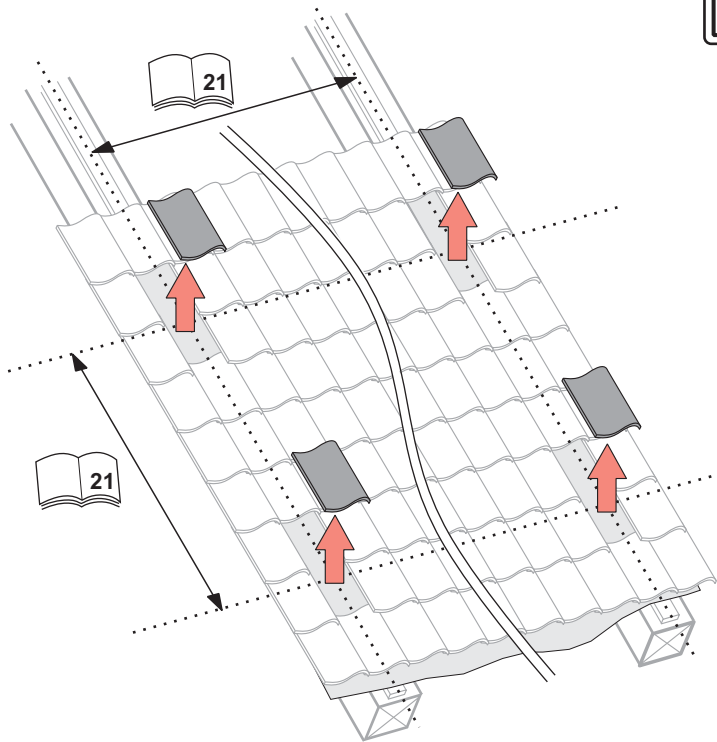

2

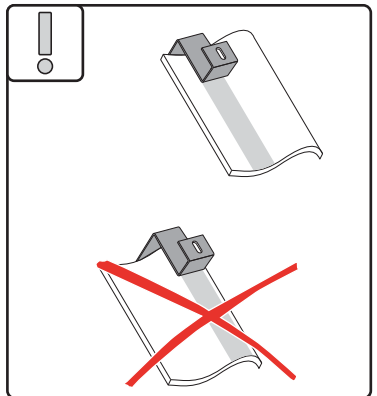
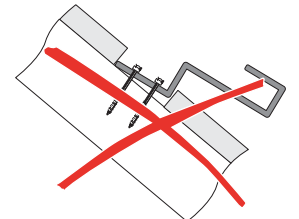
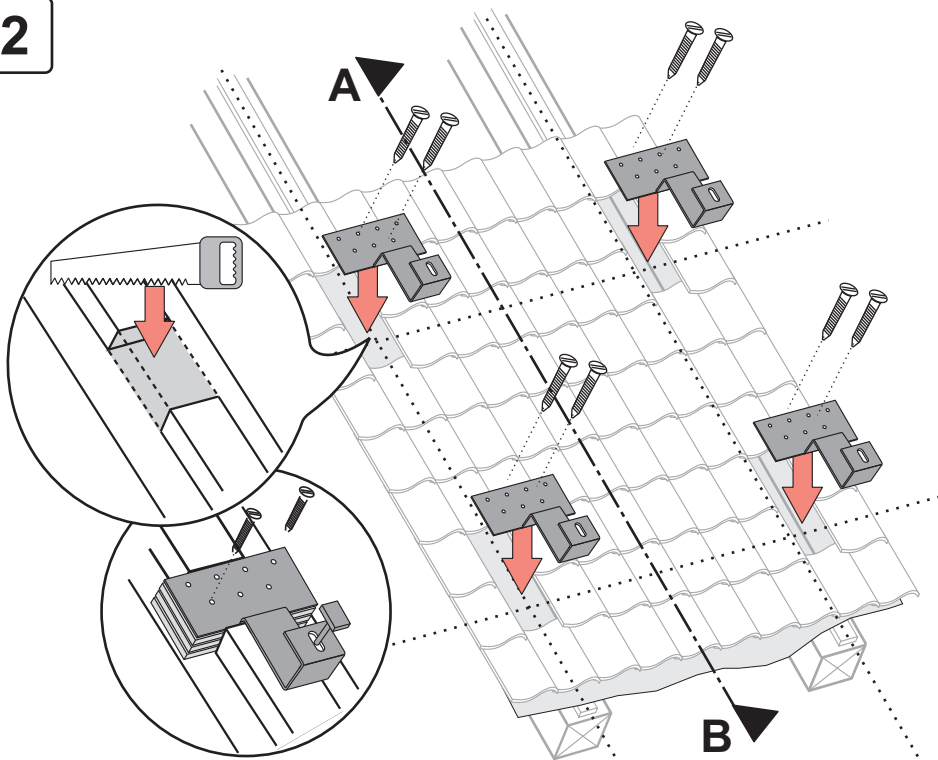

A - B

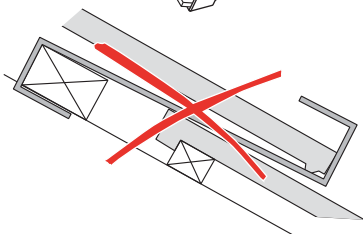

A - B OK

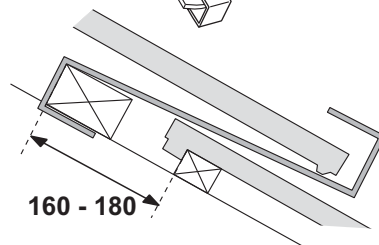

A - B

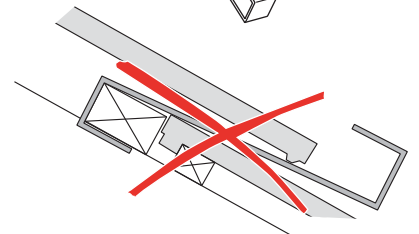

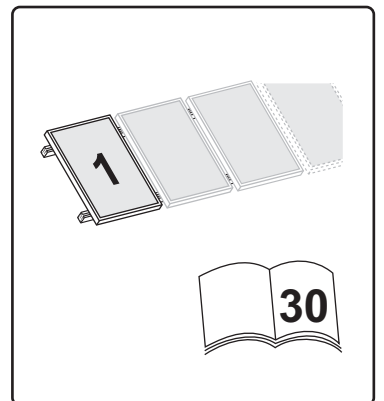
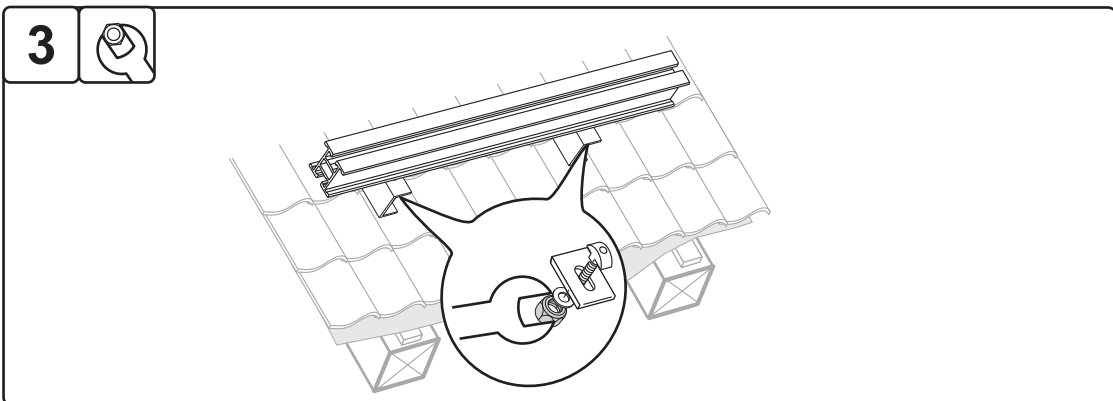
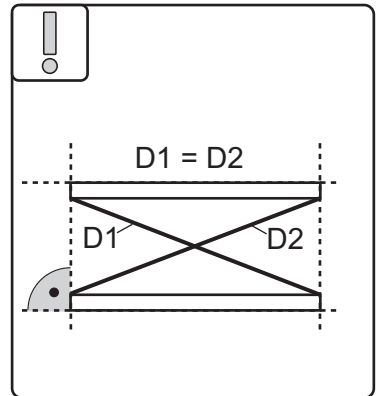
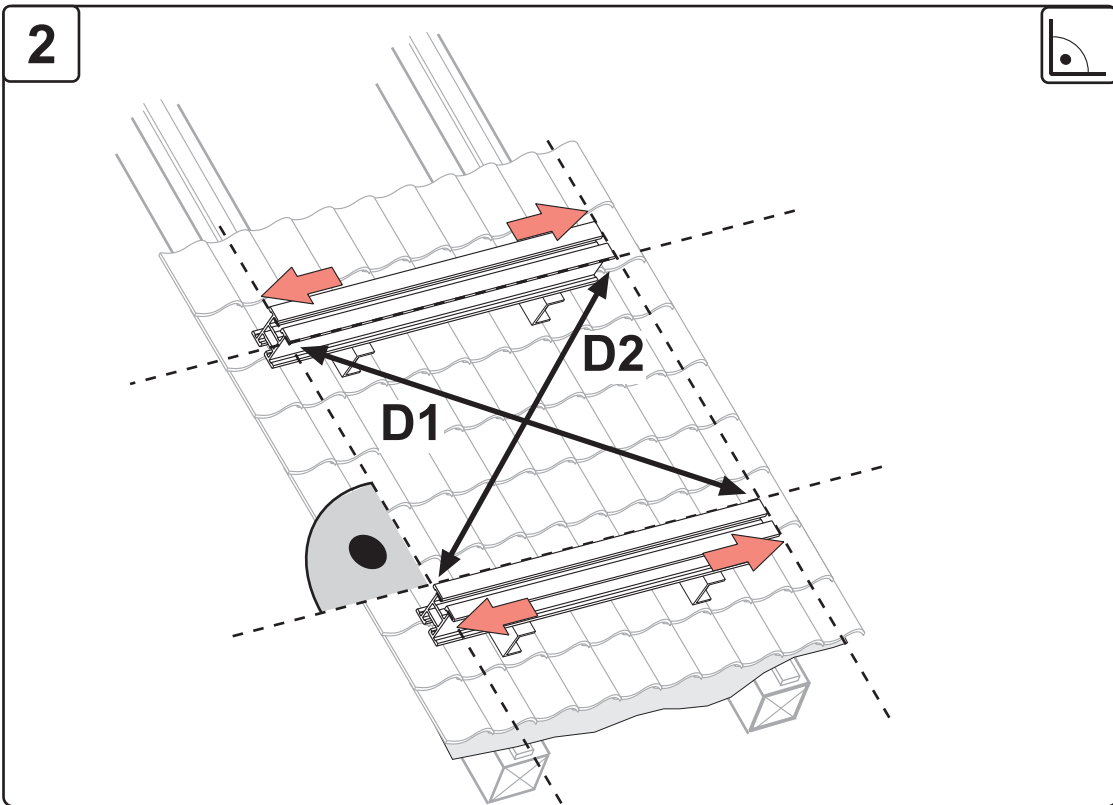
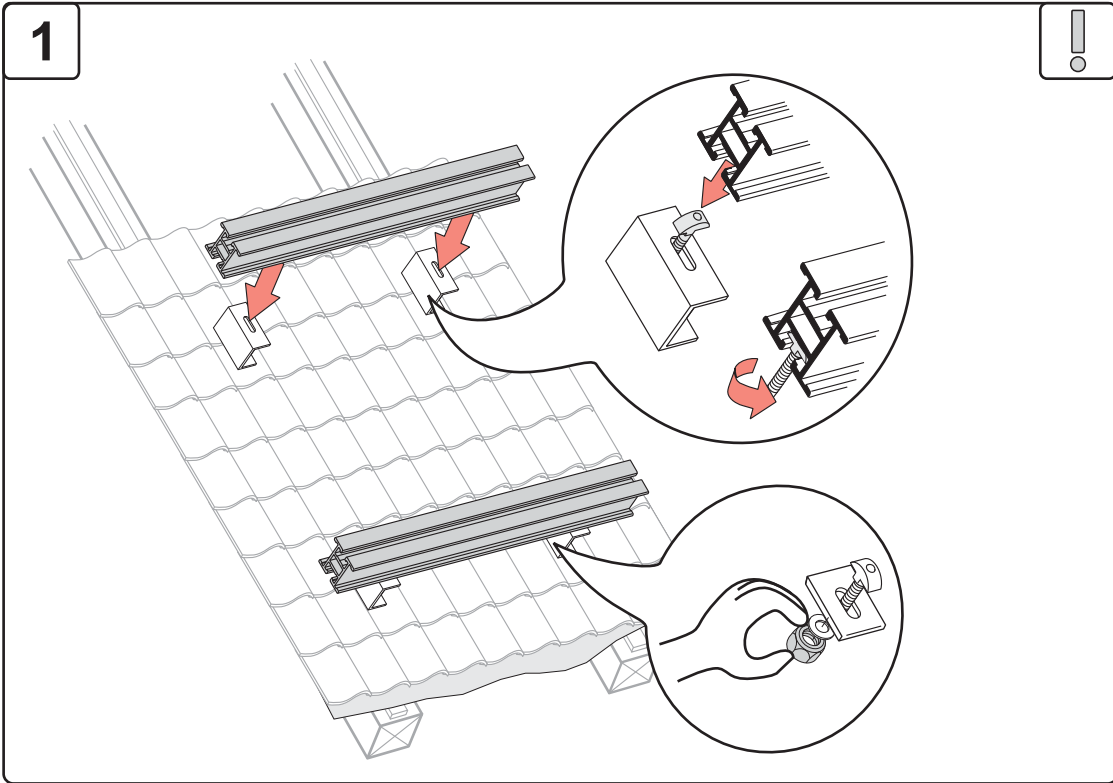
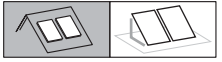

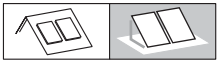

Overview: Flat-roof installation system

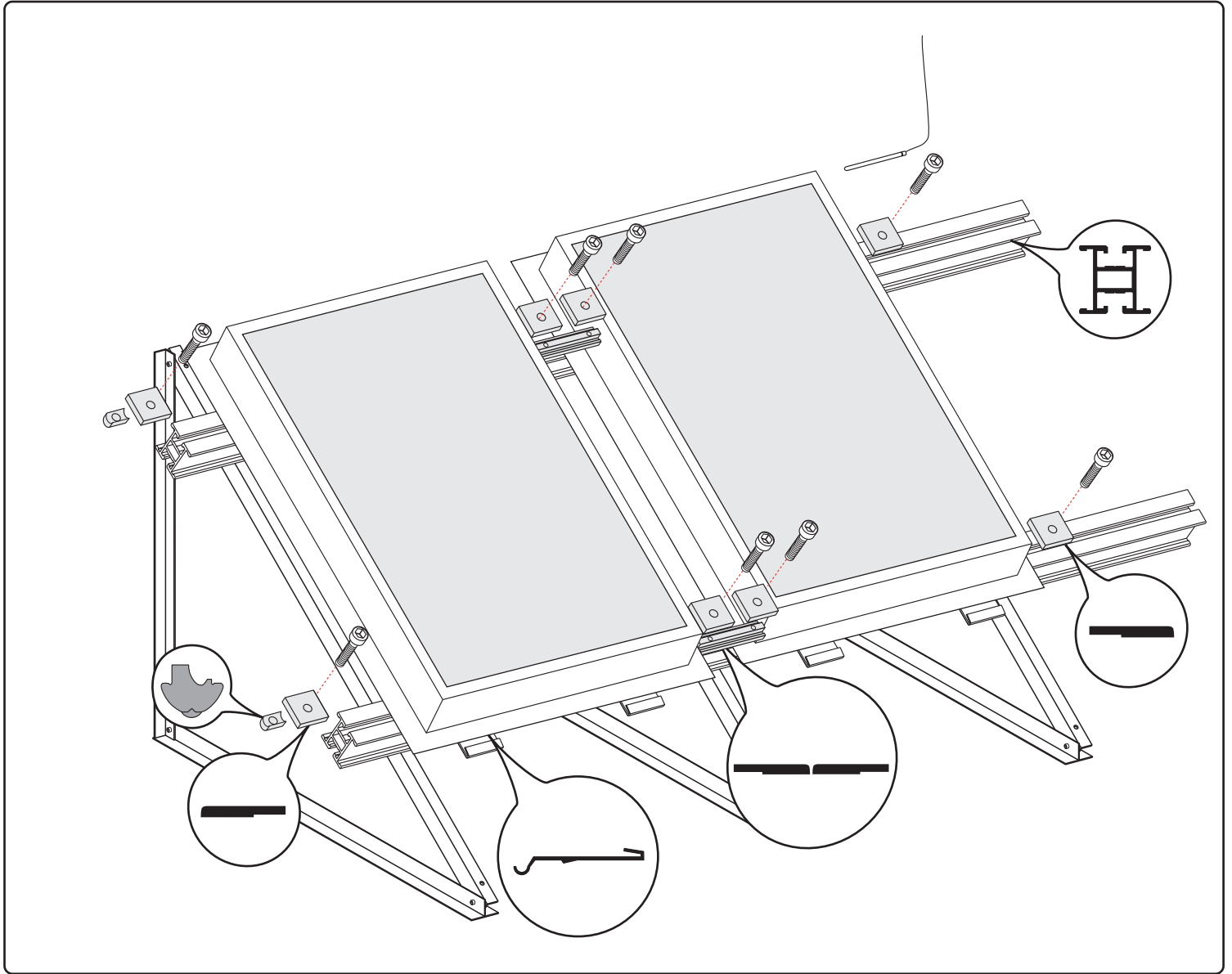

en Flat roof angle bracket
da Stativ til fladt tag
sv Stativ för platt tak

1 x

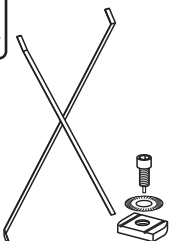
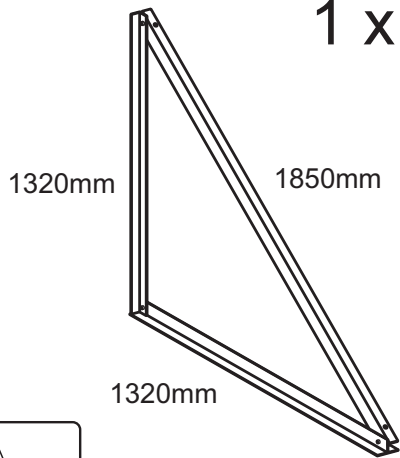

en Fit protective matting if required under the flat roof installation system
da Tilpas beskyttelsesunderlag, såfremt dette er påkrævet!
sv Läggt ett skyddande skikt på taket om det nödvändigt!

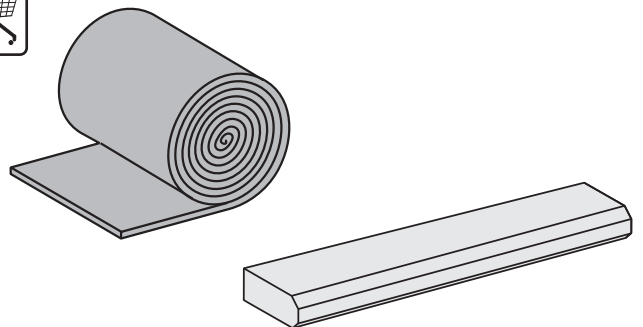
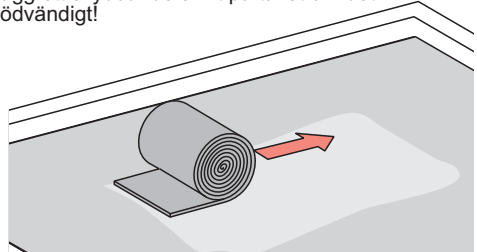



$a = 1204 \pm 100$
 $b = 2104$



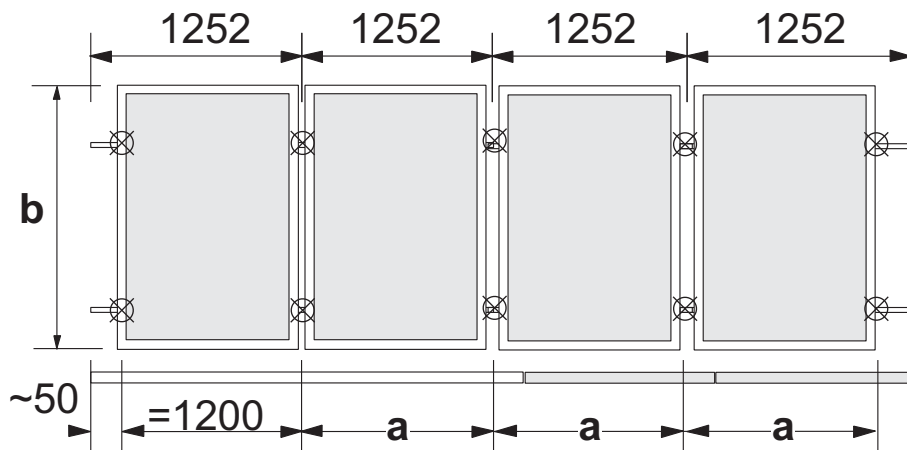
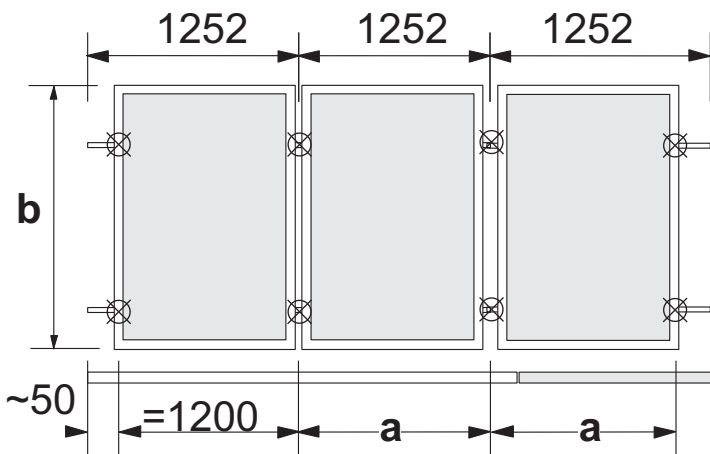
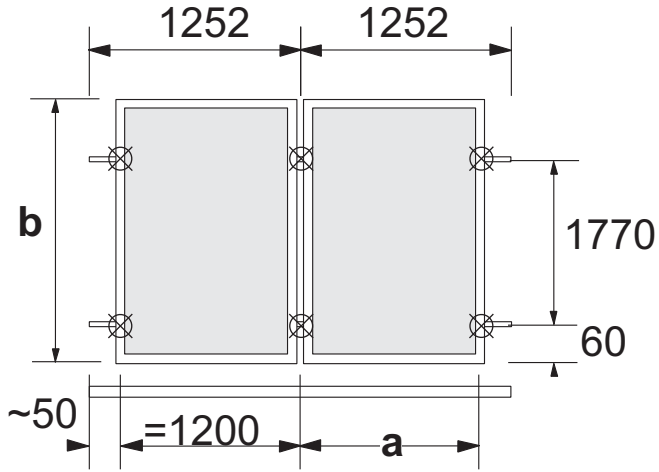
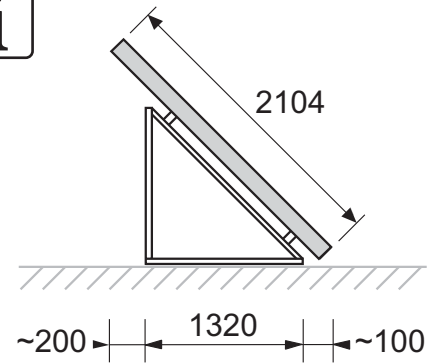



i

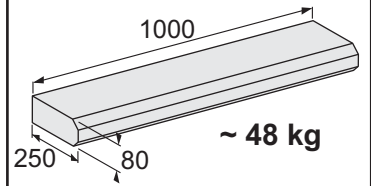
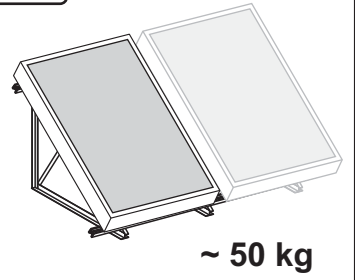
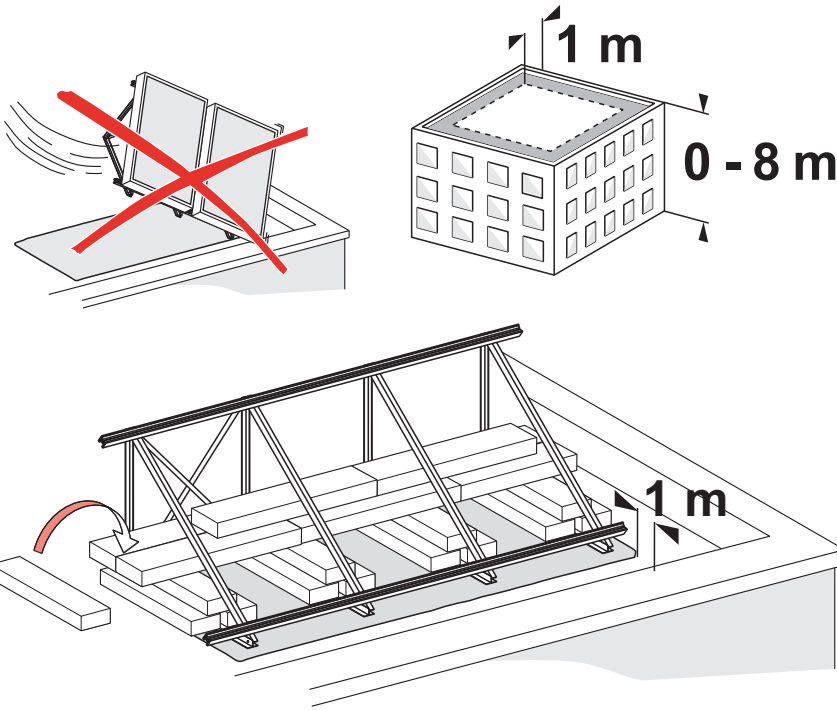

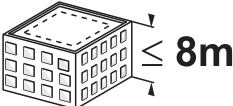
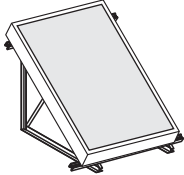
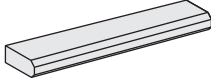
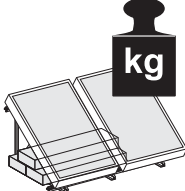
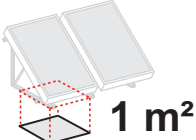

Note: Flat-roof installation system



 8m	 ~ 50 kg	 ~ 6 = ~290 kg	 ~ 340 kg	 1 m ²
	~ 50 kg	~ 6 = ~290 kg	~ 340 kg	~ 210 kg/m ²
	~ 100 kg	~ 12 = ~580 kg	~ 680 kg	~ 210 kg/m ²
	~ 150 kg	~ 18 = ~860 kg	~ 1010 kg	~ 210 kg/m ²
	~ 200 kg	~ 24 = ~1150 kg	~ 1350 kg	~ 210 kg/m ²
	~ 250 kg	~ 30 = ~1440 kg	~ 1690 kg	~ 210 kg/m ²

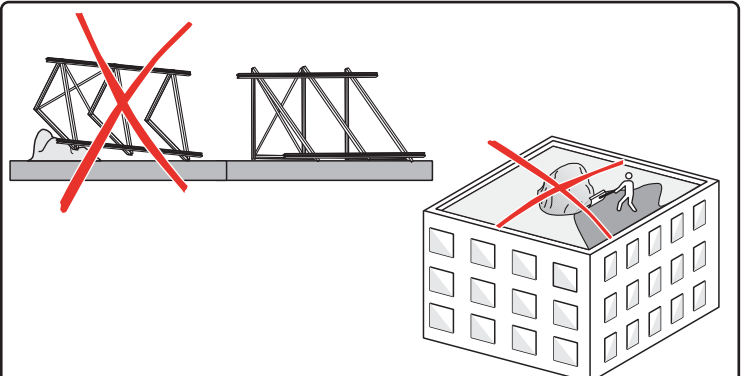
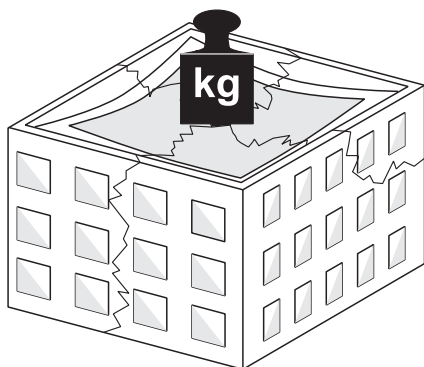



4

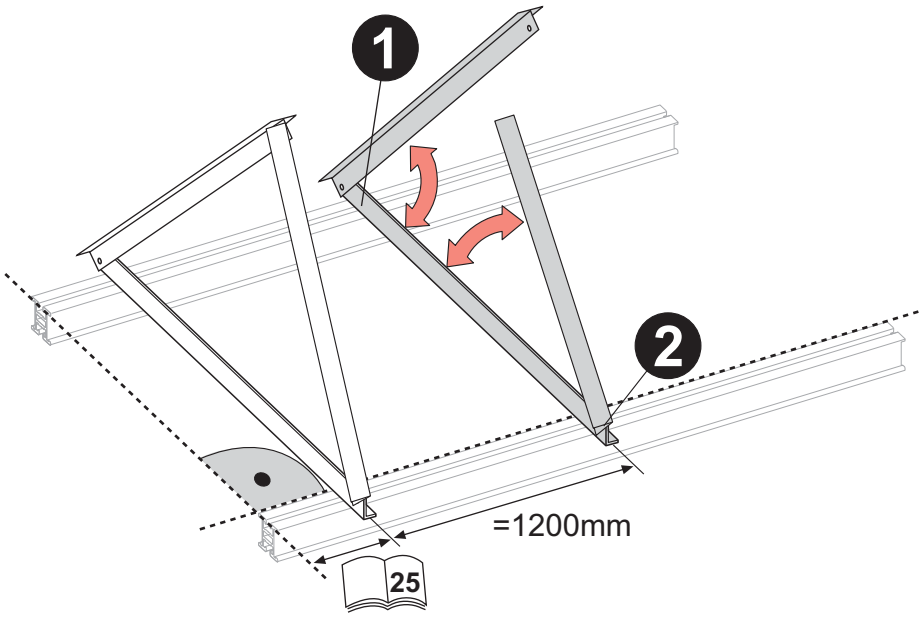

1

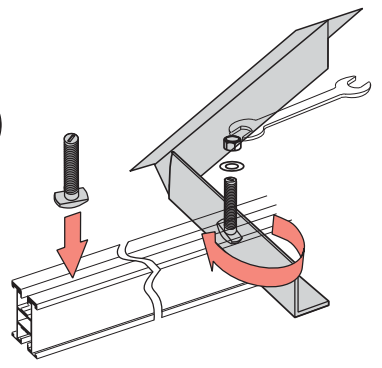

2

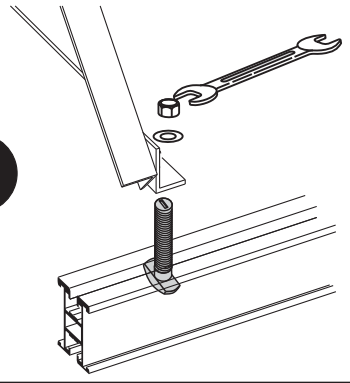

5

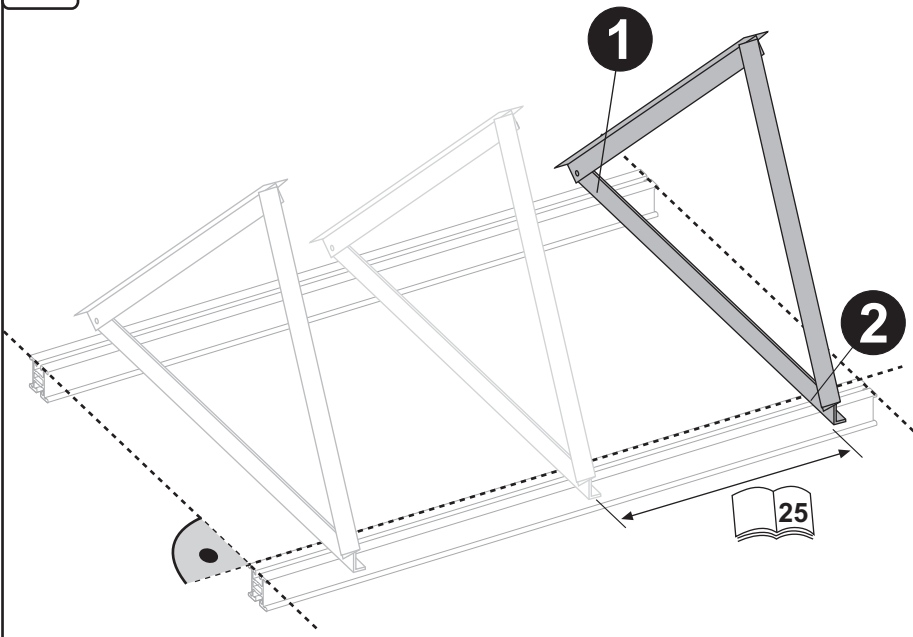

1

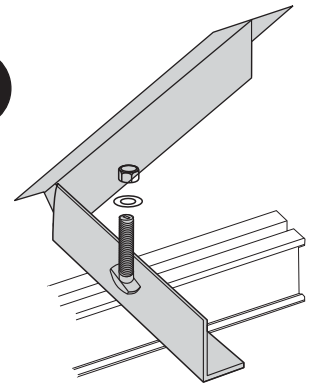

2

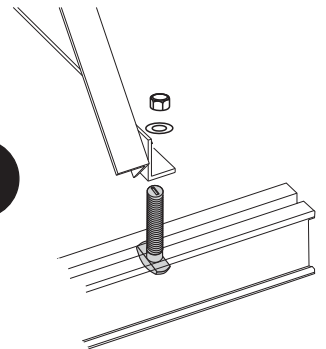

i

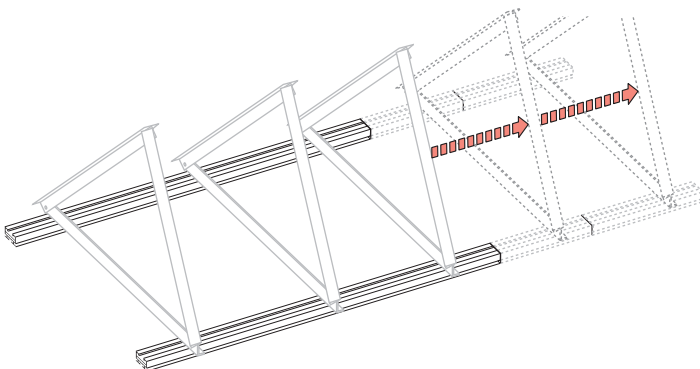

i

36

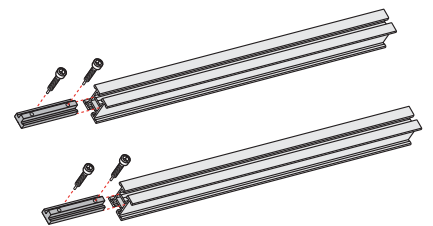

6**i**

- en Fix the brackets statically safe to the ground. (see note p. 26)
- da Fikser stativet så det står sikkert og stabilt på underlaget (se note s. 26)
- sv Fixera stativet så att det står säkert och stabilt på underlaget (se sidan 26)



Collector installation: horizontal base rails

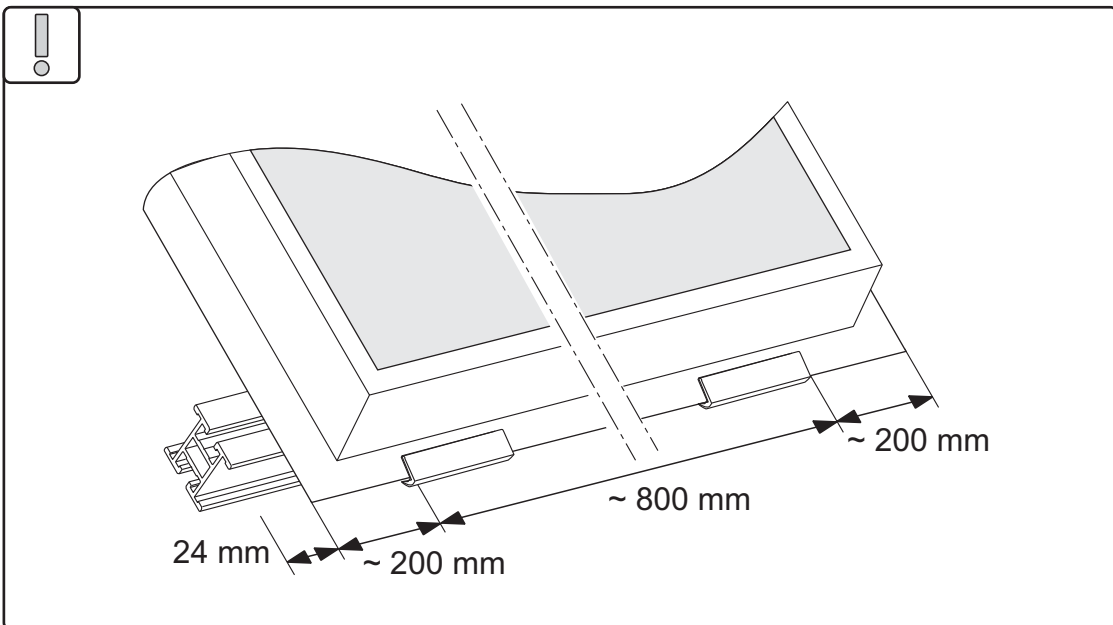
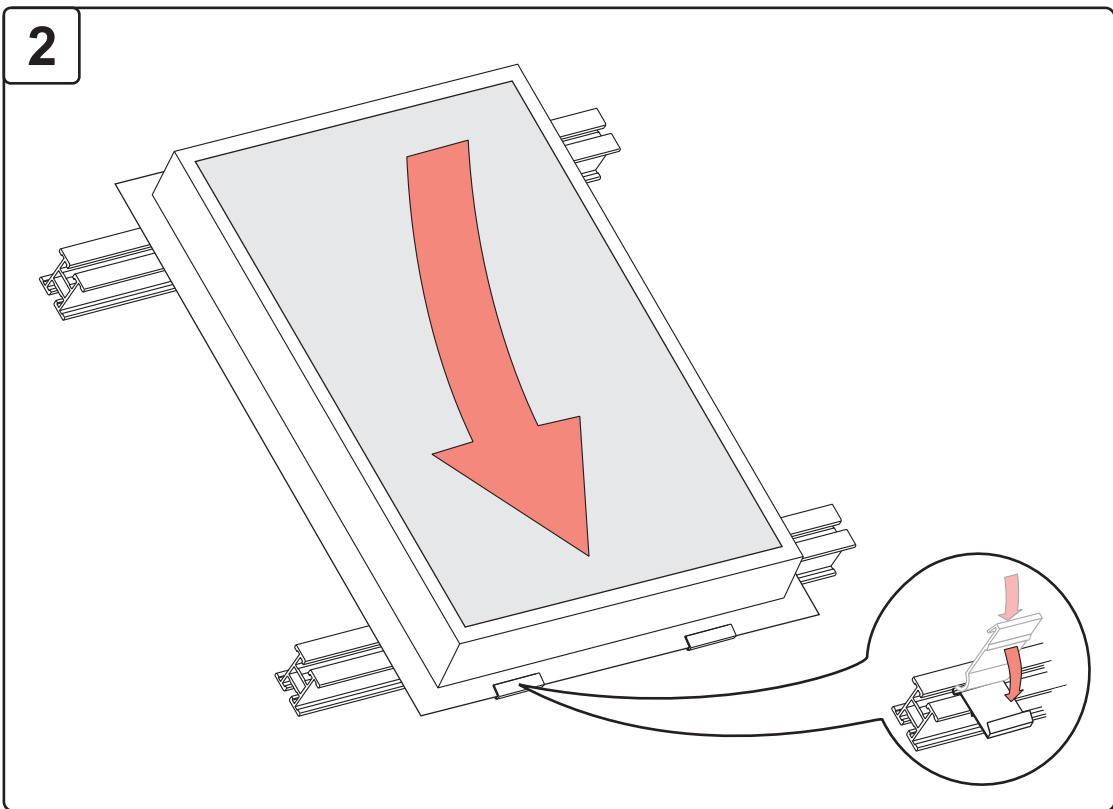
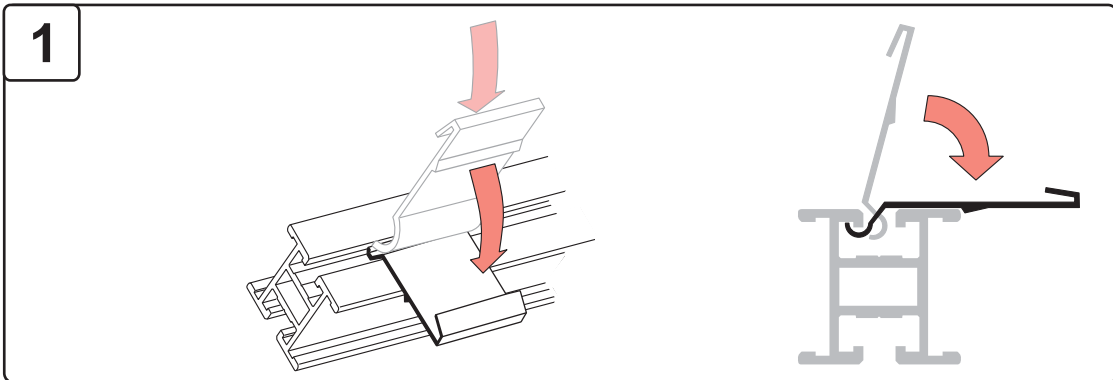
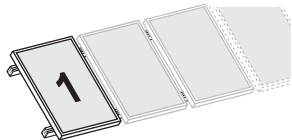

3

a

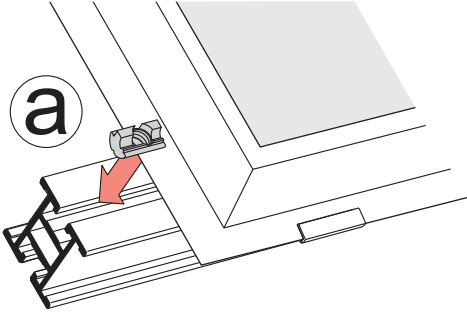

b

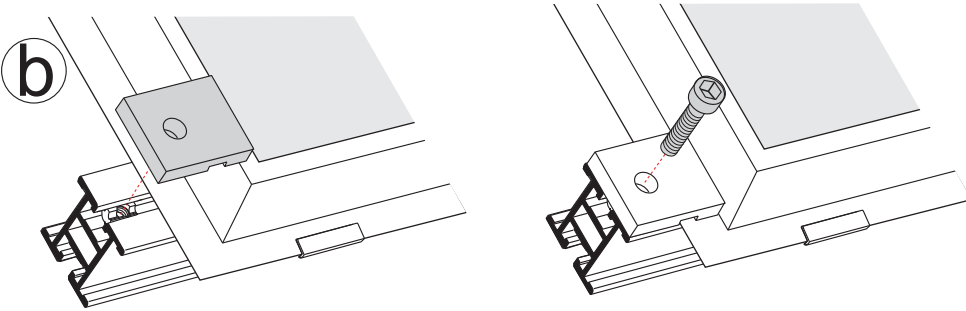

i

a

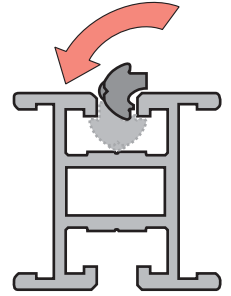
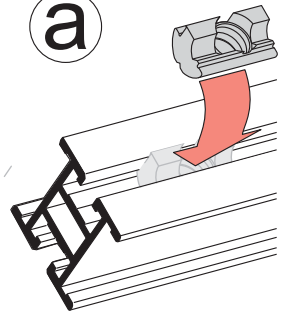

4

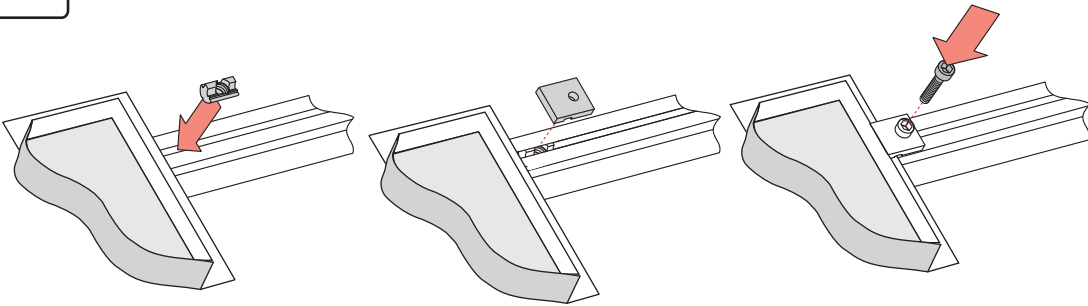

i

b

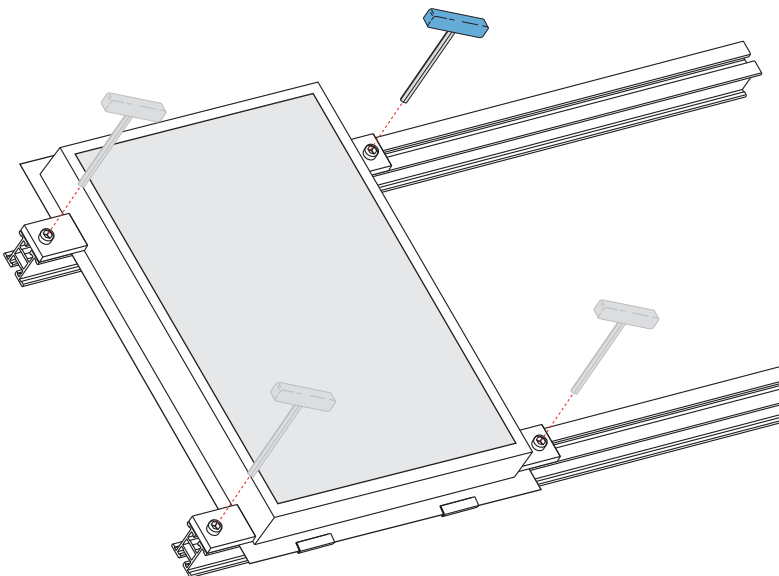
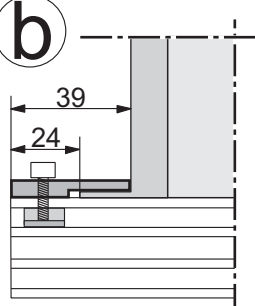

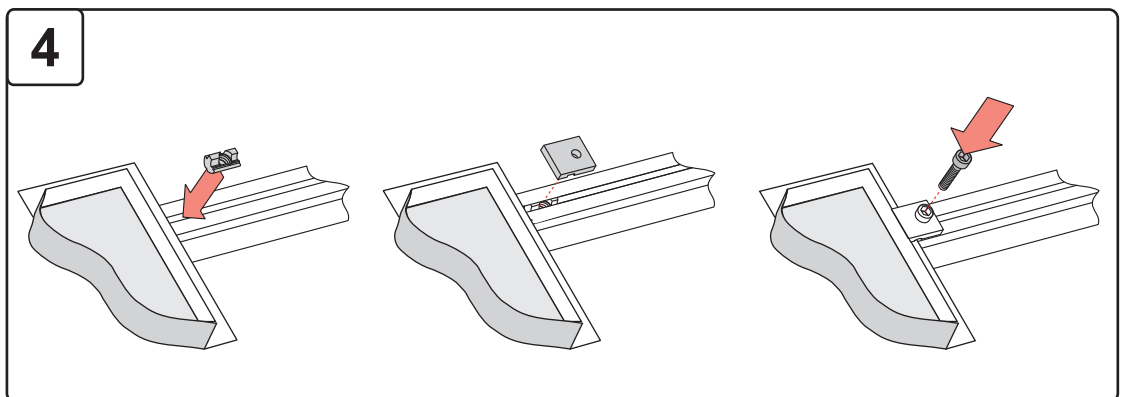
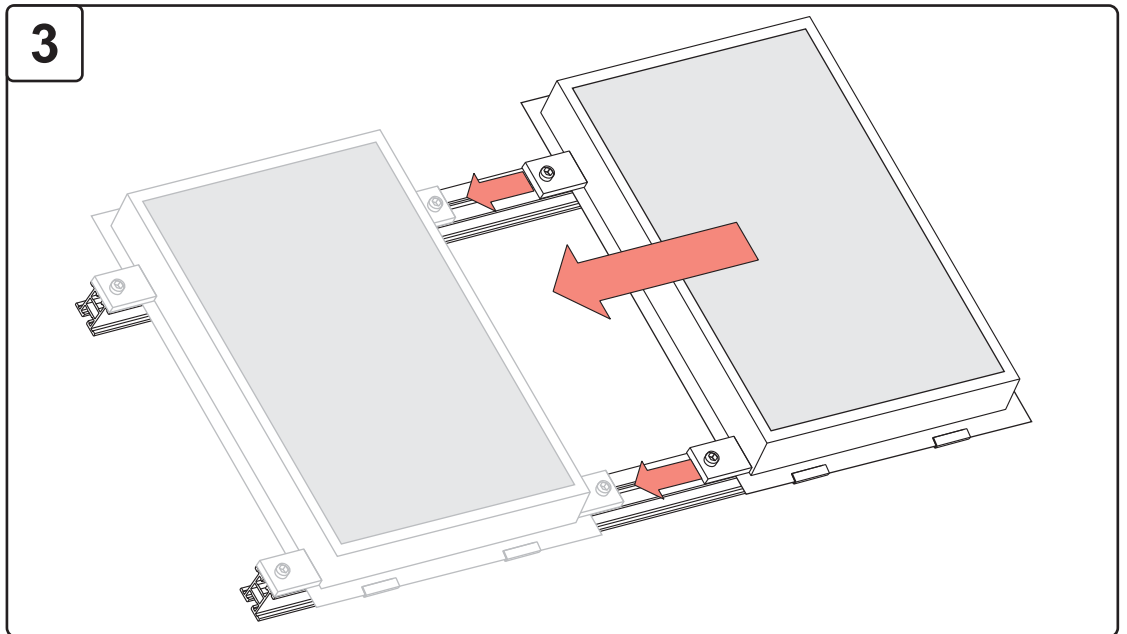
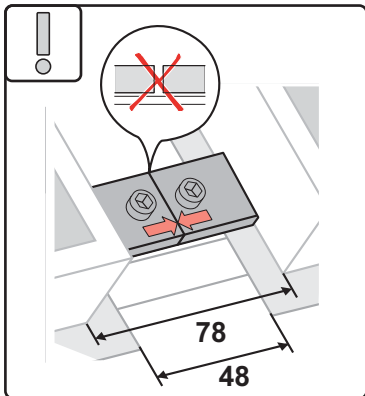
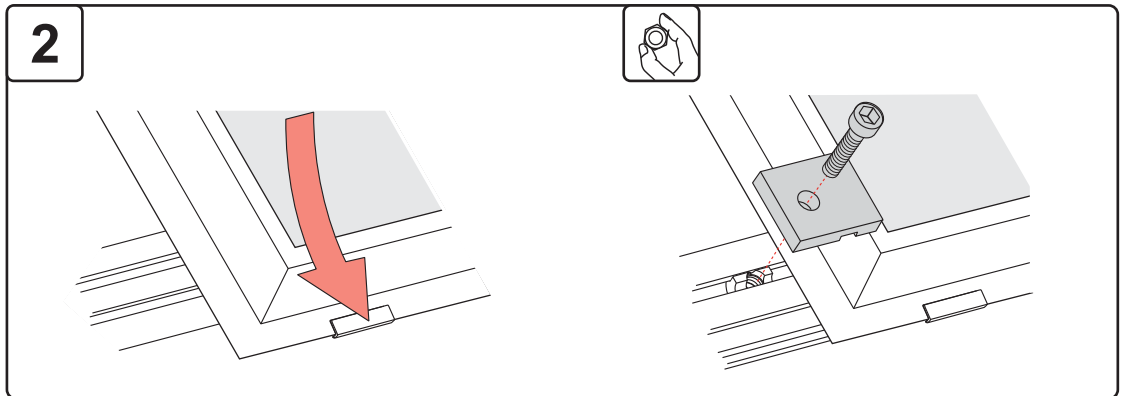
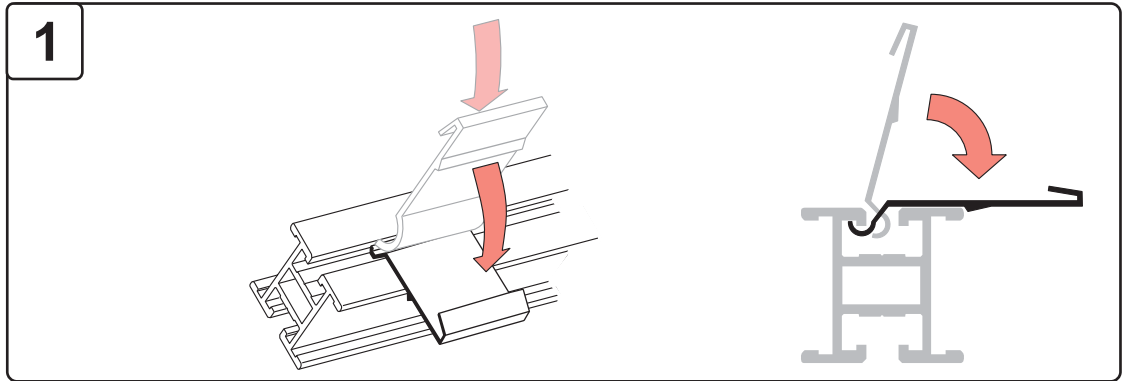

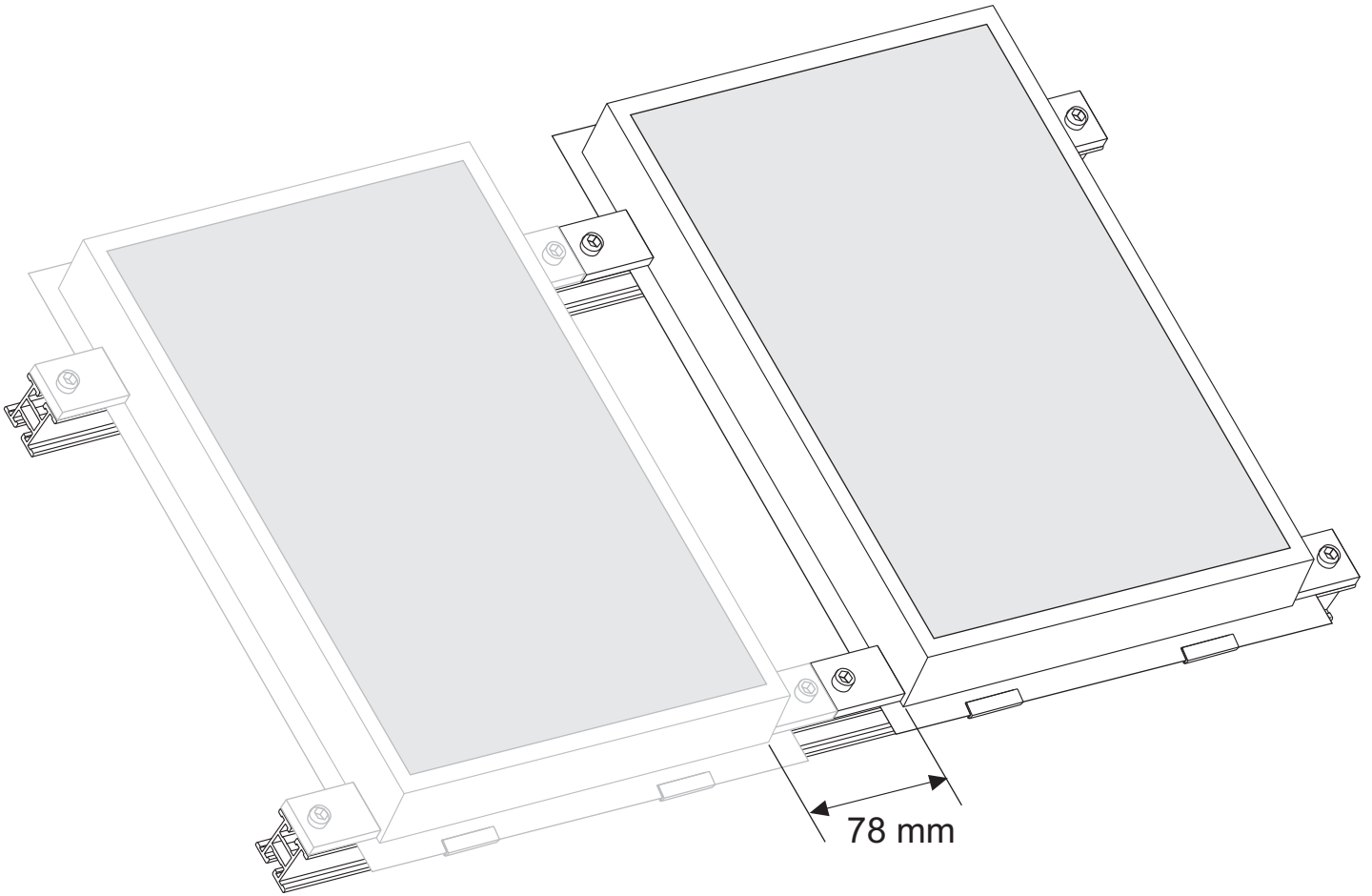

5

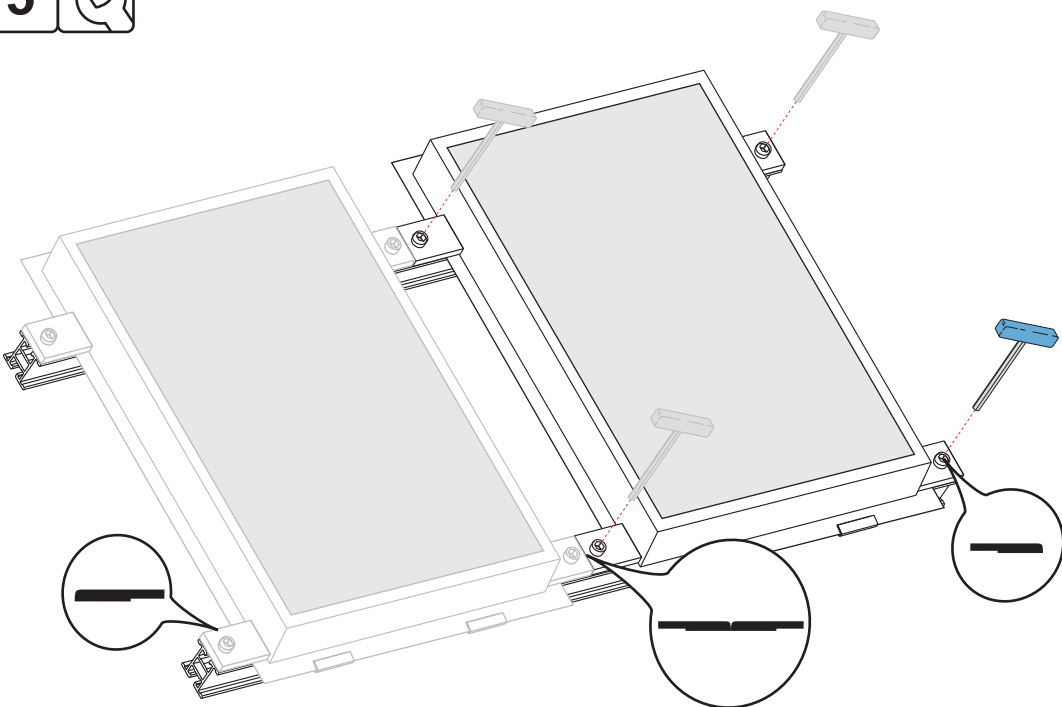

i

32

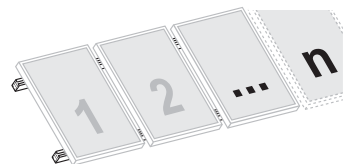



i

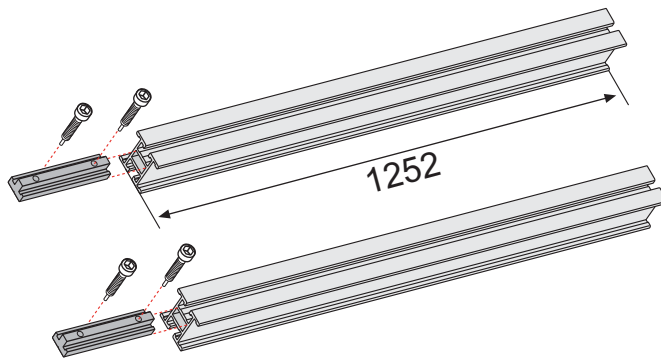

1

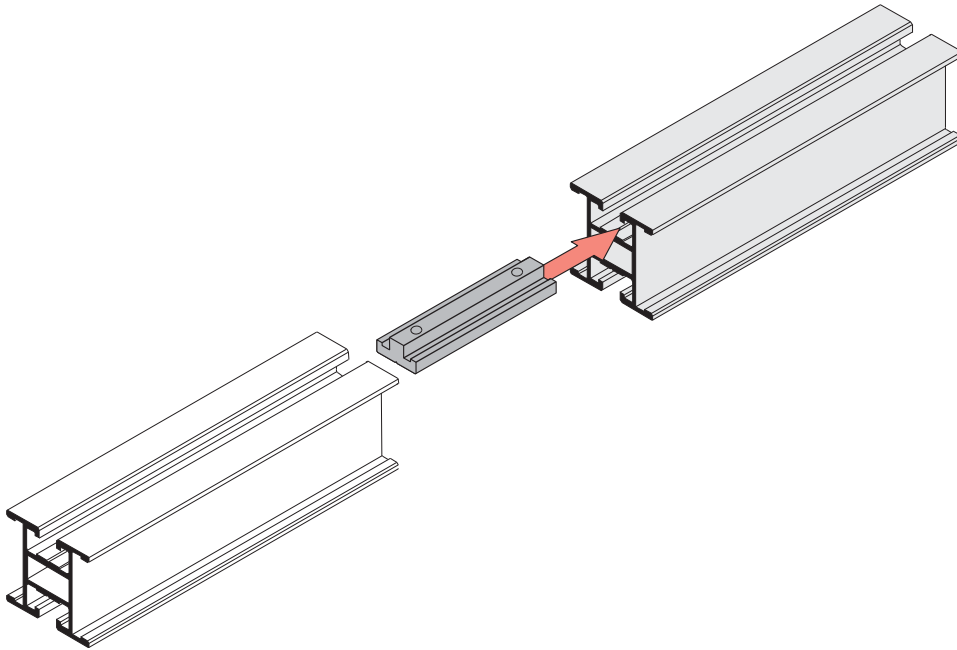

2

- en At the end of the collector array, you have to slide the "anchor block connector" shortly into the base rail and fasten it, or you may use a standard anchor block
- da I yderste del af panelet , skal anker-blok-adaptoren glide et lille stykke ind i skinnen og fastgøres, eller også kan den normale anker-blok anvendes
- sv I änden av monteringsknan skall kopplingsbeslaget skjutas in en liten bit och skruvas fast

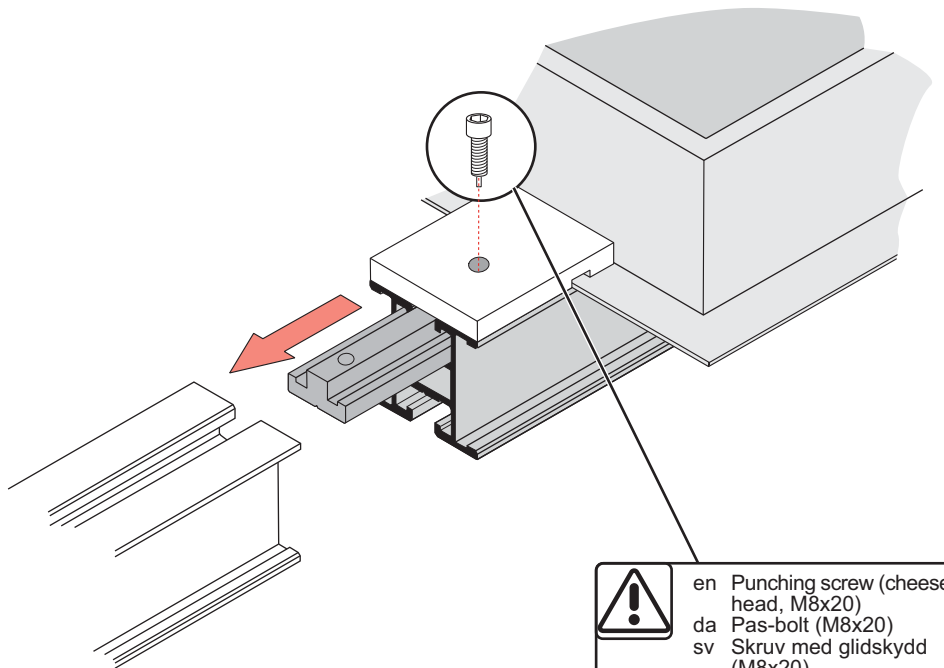

- en Punching screw (cheese head, M8x20)
- da Pas-bolt (M8x20)
- sv Skruv med glidskydd (M8x20)

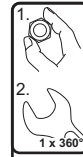
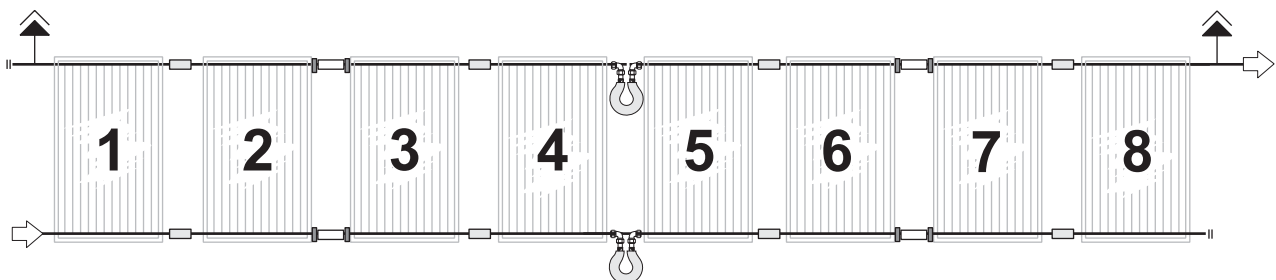
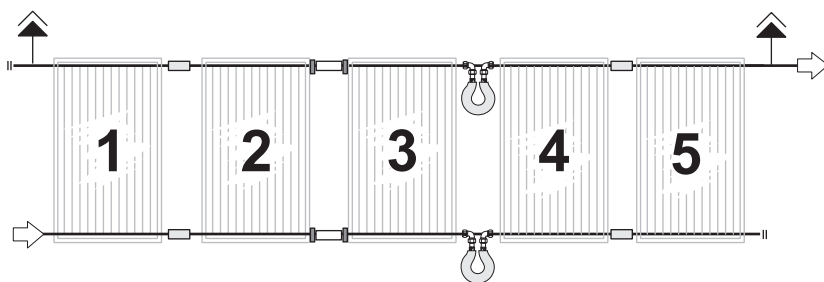
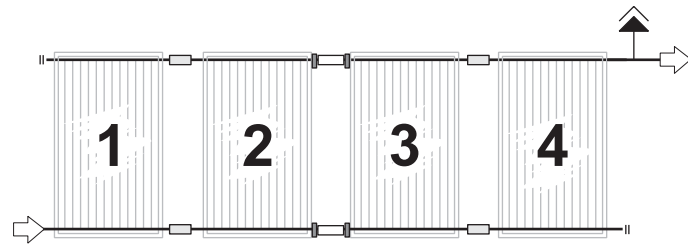
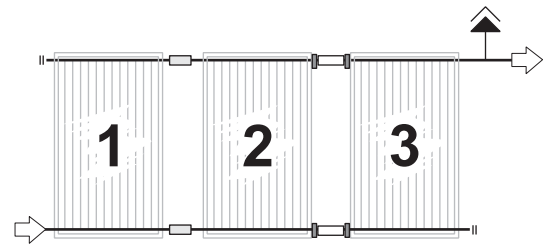
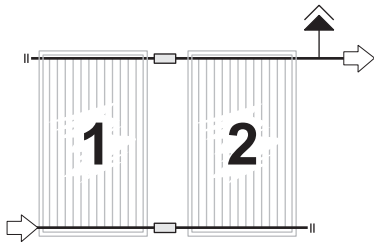

Hand-tighten the screw connection and then tighten fully with a 360° turn

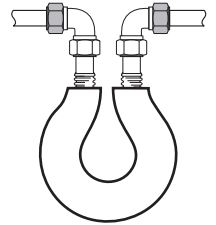

en breather symbol
da Symbol udlufter
sv Symbol avluftning

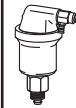

en Solar breather
da Solarudlufter
sv Avluftare för solsystem



en temperature stability = 160°C
da Anvendelig ved temperatur = 160°C
sv Användbar vid temperatur = 160°C

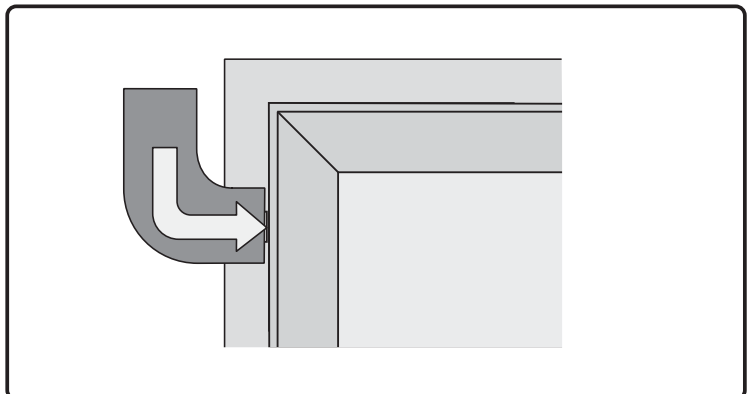
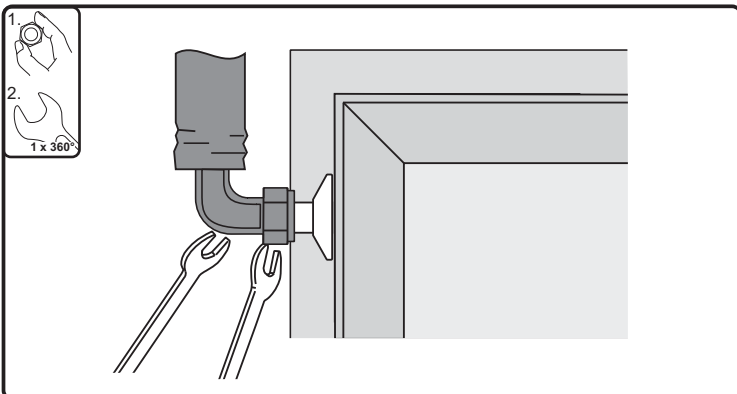
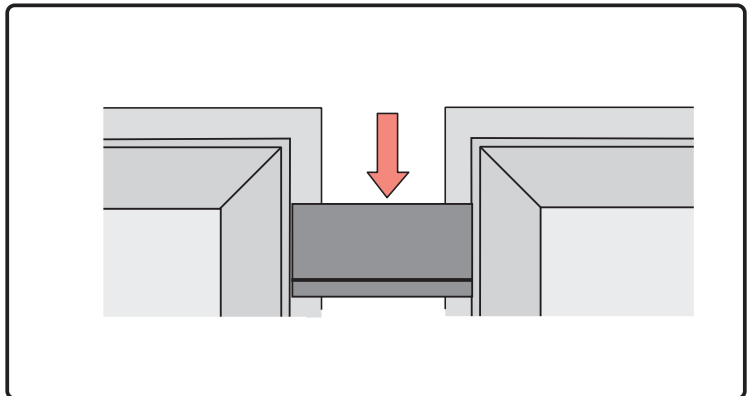
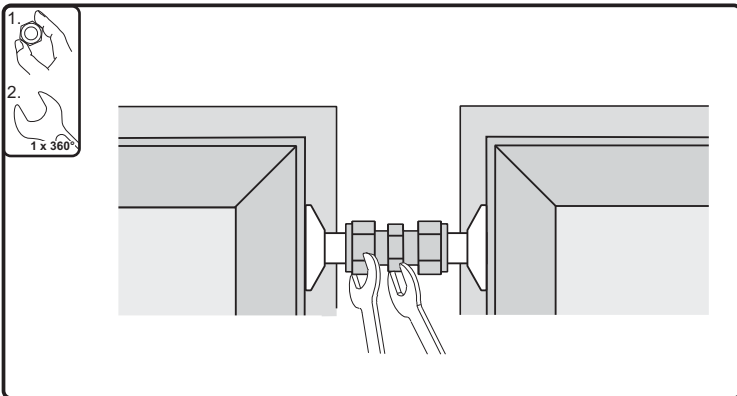
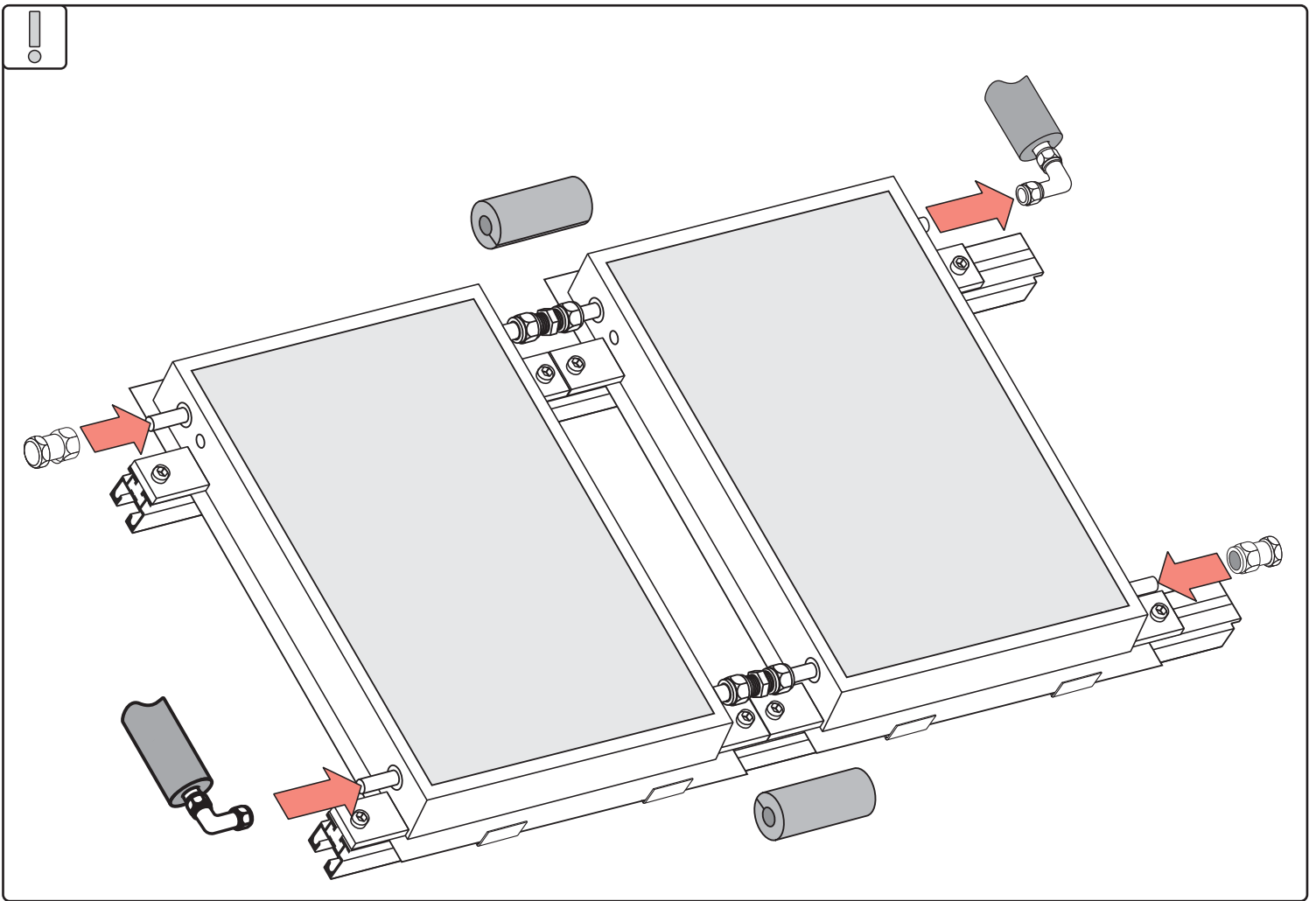
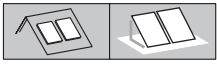

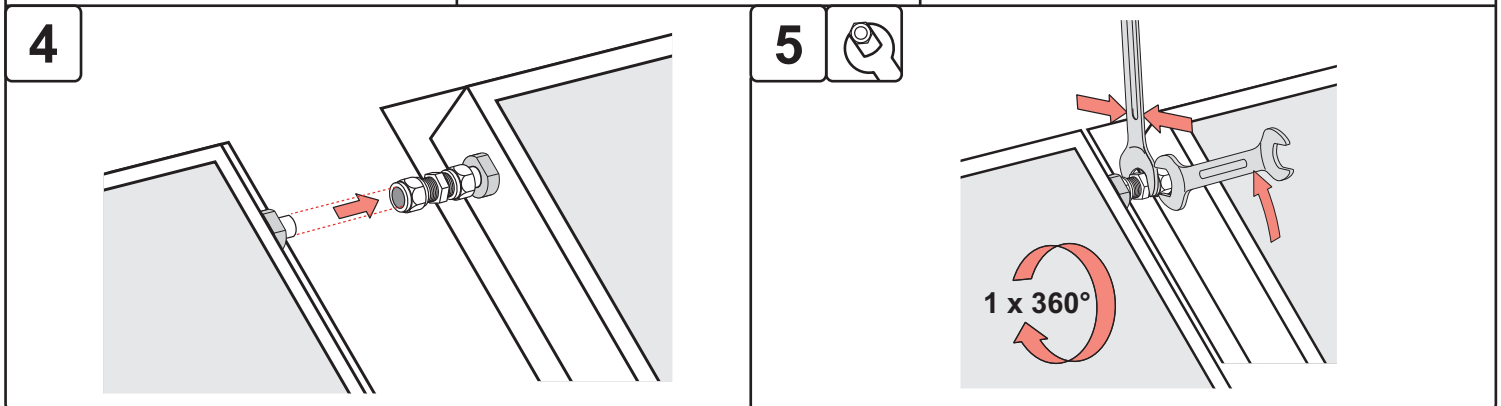
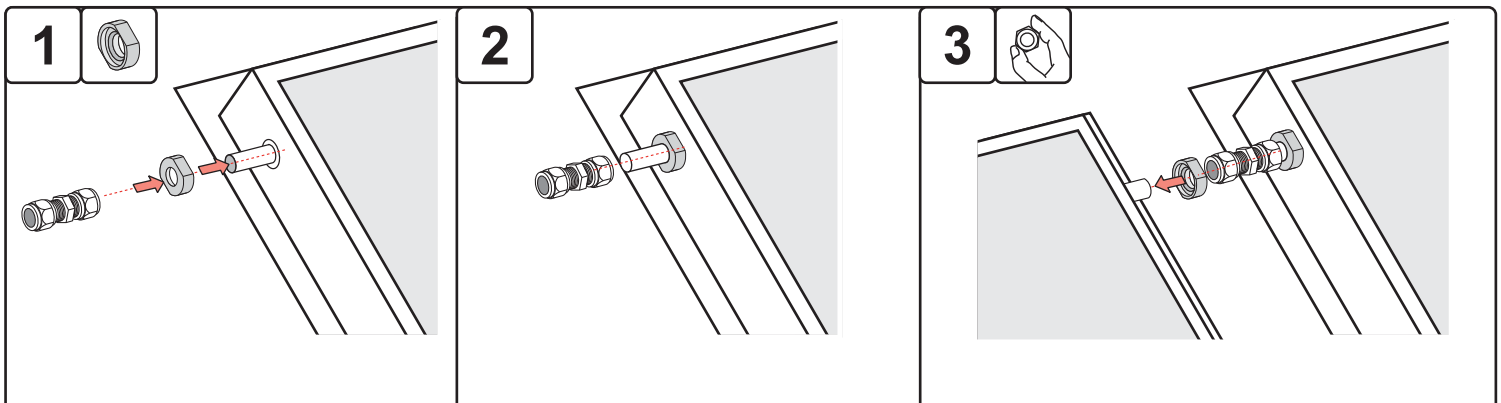
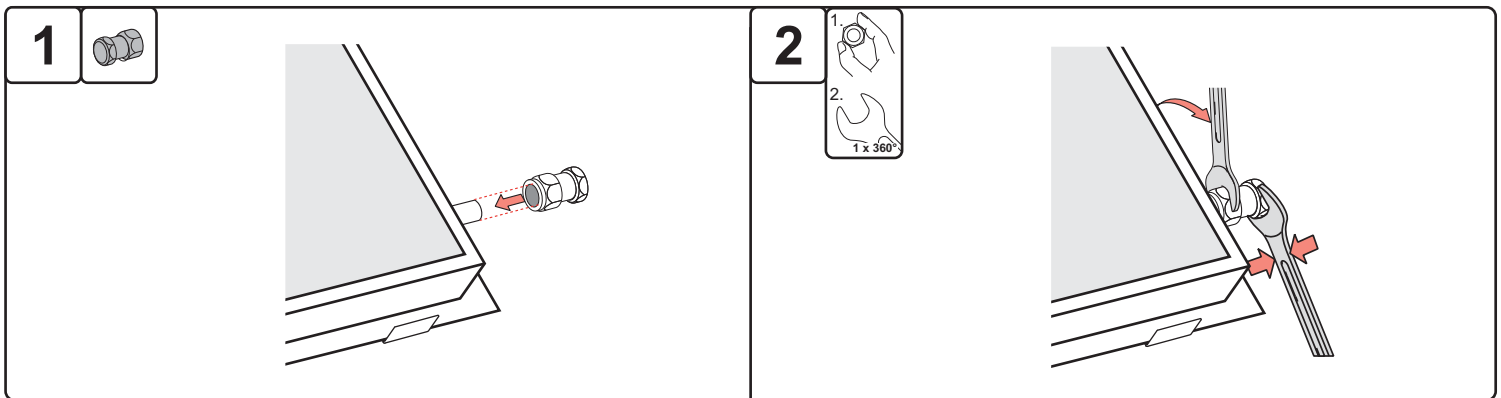
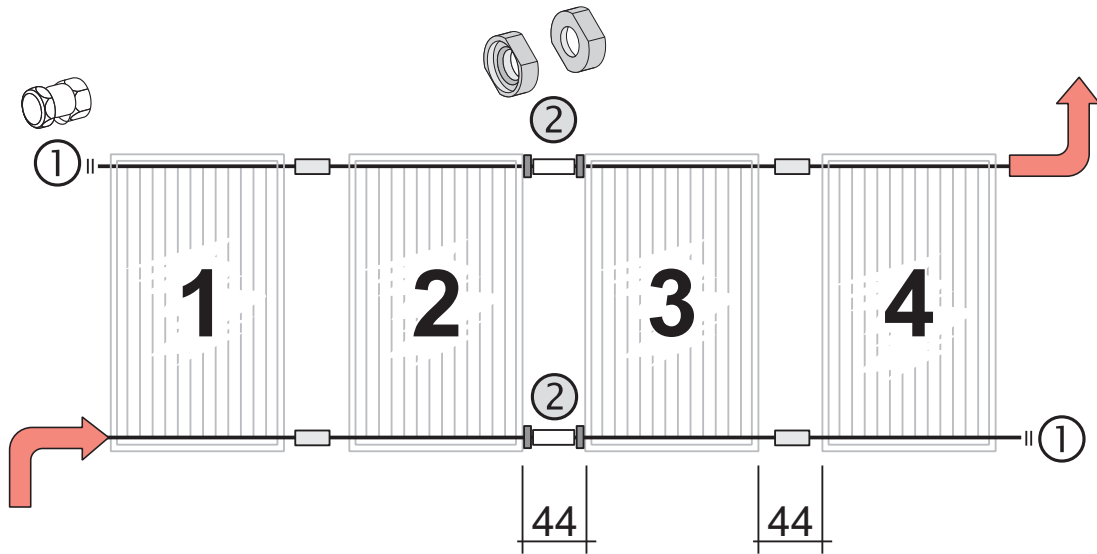



Note: Position of the on-roof breather



en used Symbols
da Anvendte symboler
sv Använda symboler



en bushing
da Bøsning
sv Rak anslutning



en Solar circuit, flow
da Solvarme, fremløb
sv Solvärmekrets, tillopp



en Breather
da Udlufter
sv Avluftare



en Solar circuit, return
da Solvarme, retur
sv Solvärmekrets, retur



en three-way fitting
da 3-vejs fitting (Tee-rør)
sv Trevägsanslutning, T-rör

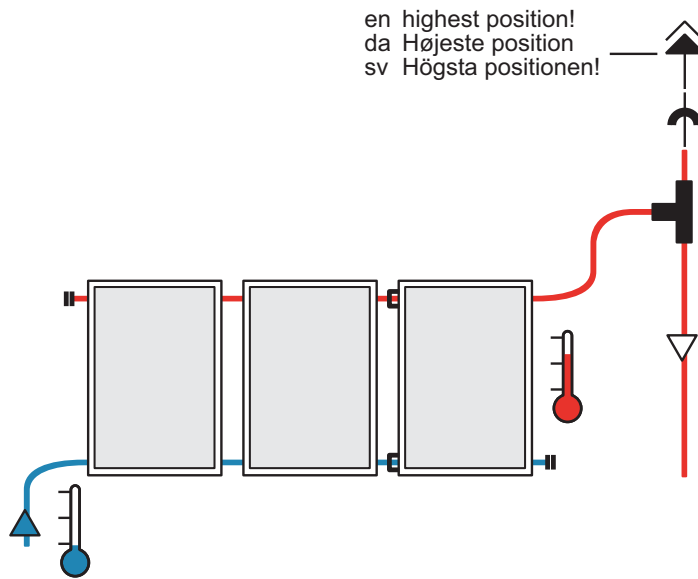

Also required:



en three-way fitting
da 3-vejs fitting (Tee-rør)
sv Trevägsanslutning, T-rör



en bushing
da Bøsning
sv Rak anslutning



en Breather (NB. Not necessary to use with the pump-block from BAXI)
da Udlufter (NB. Ikke nødvendig ved brug af BAXI pumpegruppe!)
sv Avluftare (Obs! Inte nödvändig med Baxi pummgrupp som har integrerad avluftning)



en copper pipe 18x1 mm; 5 - 10 cm length
da Kobberrør 18x1 mm; længde 5-10 cm
sv Kopparrör 18x1, längd 5-10 cm

en suitable seal material for the pressure tight execution of bolt connections
da Et passende tætningsmateriale for en tryktæt udførsel af boltforbindelsen.
sv Ett passande tätningmaterial för trycktäta anslutningar.

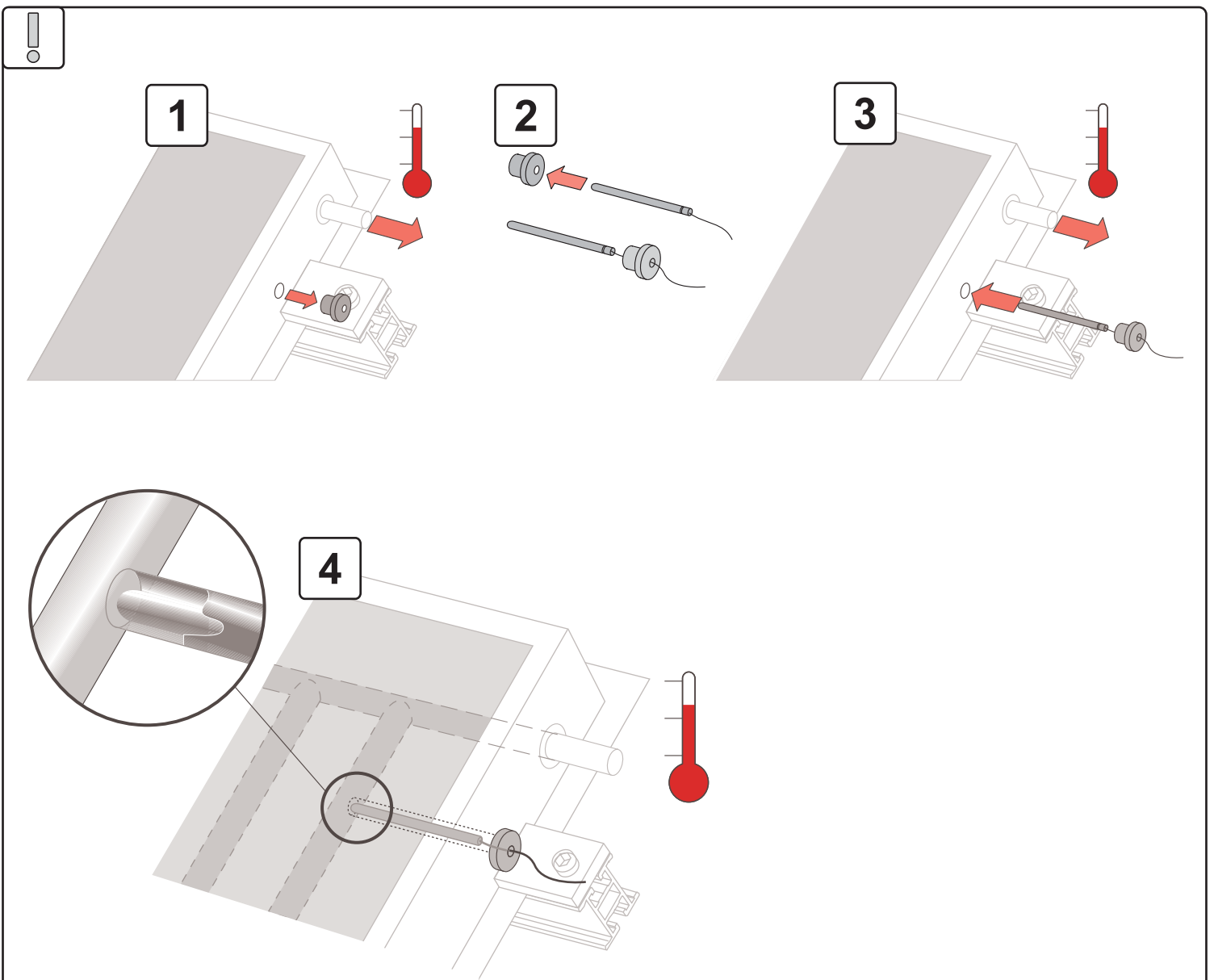
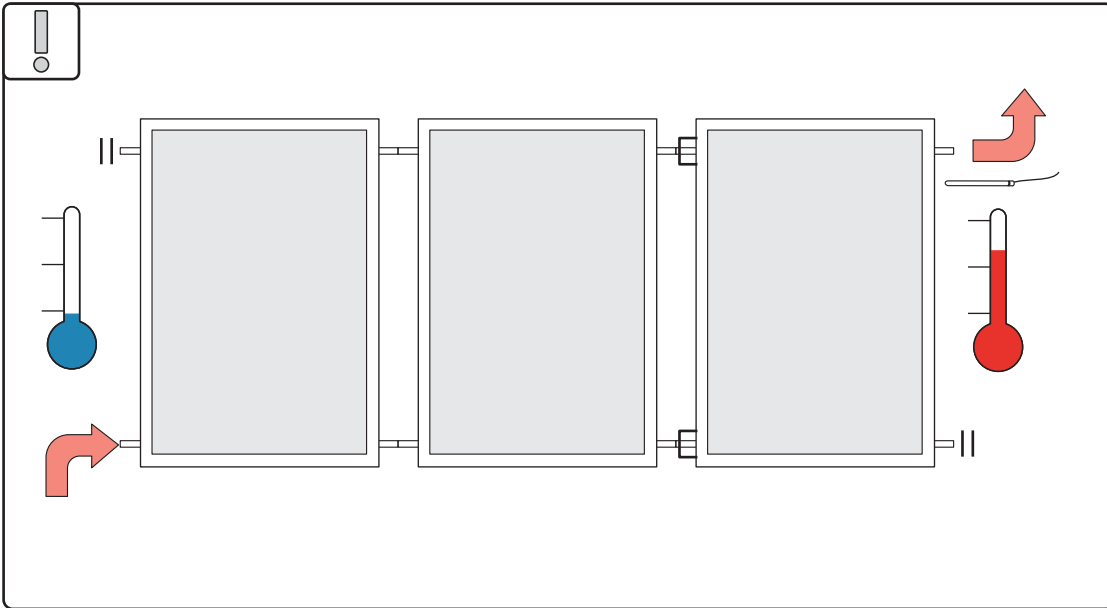

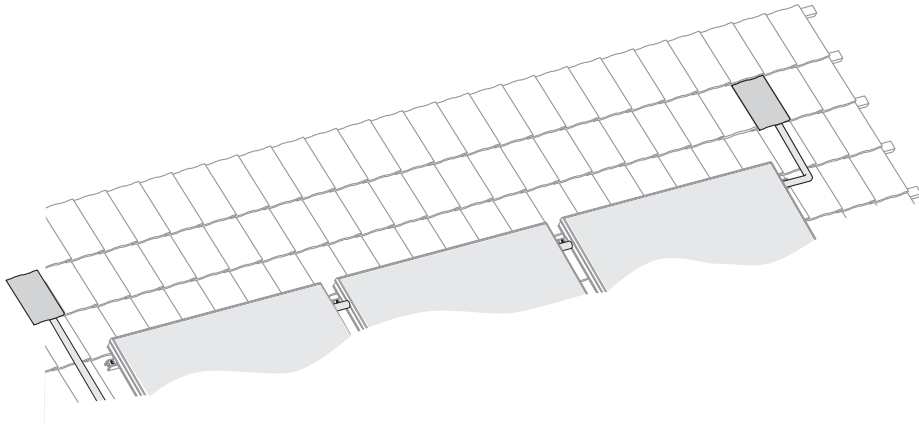
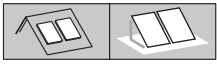

A - B

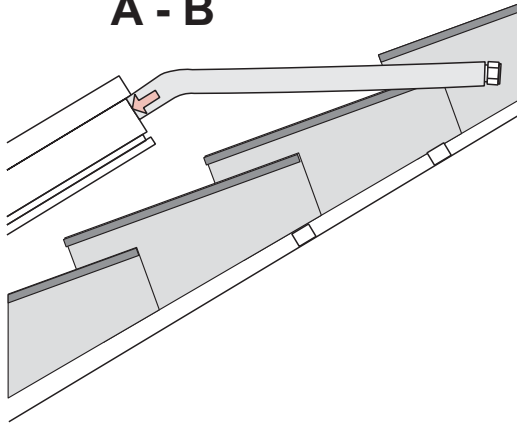

A

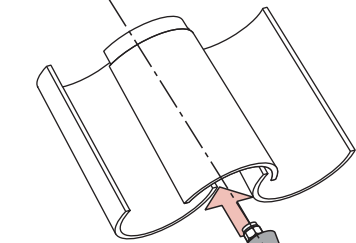

B



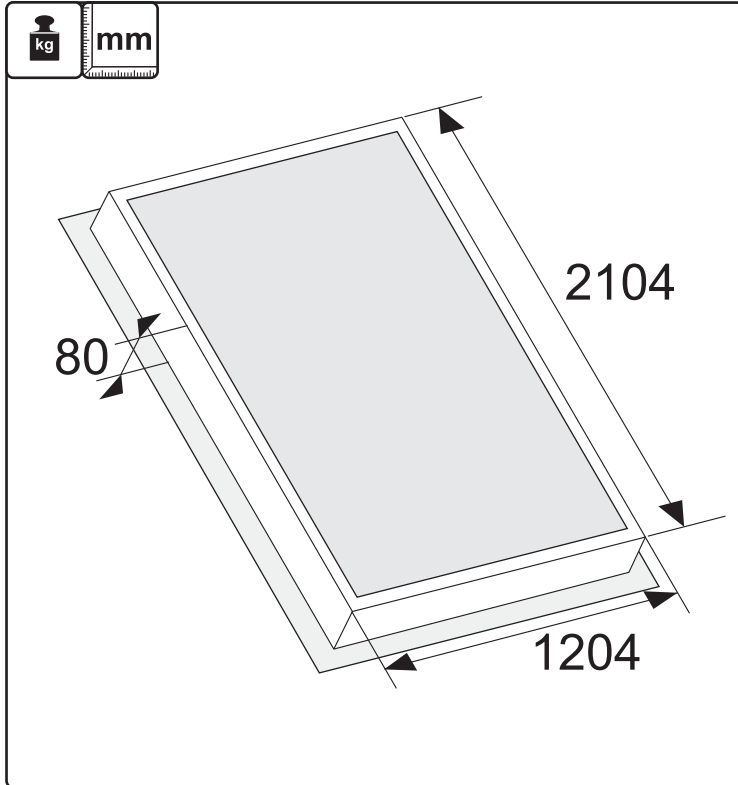

en	=	
Dead load	=	44 kg
Collector surface	=	2,50 m ²
Absorber surface	=	2,36 m ²
min. volume flow rate(Vmin)	=	1,67 l/min
Thermal rating	=	1,5 kW
Connection	=	4 x 18 mm Cu-Rohr
Pressure drop (Vmin)	=	1,1 mbar (bei 20°C)
max. Operating pressure	=	10 bar
Shutdown-temperature	=	209 °C
thermal insulation	=	40 mm

da	=	
Vægt (tom)	=	44 kg
Overflade solpanel	=	2,50 m ²
Overflade absorber	=	2,36 m ²
Min. Volumen strøm (Vmin)	=	1,67 l/min
Termisk klassificering	=	1,5 kW
Rør-forbindelse	=	4 x 18 mm Cu-Rohr
Tryktab	=	1,1 mbar (20°C)
Max. anvendelsestryk	=	10 bar
Nedlukningstemperatur	=	209 °C
Isolering	=	40 mm

sv	=	
Vikt (tom)	=	44 kg
Solfångararea	=	2,50 m ²
Absorbatorarea	=	2,36 m ²
Min. Flöde (Vmin)	=	1,67 l/min
Termisk klassificering	=	1,5 kW
Röranslutning	=	4 x 18 mm Cu-Rohr
Tryckfall	=	1,1 mbar (20°C)
Max. driftstryck	=	10 bar
Avstängningstemperatur	=	209 °C
Isolering	=	40 mm

en Commissioning

Following installation of the solar panels and hydraulic connection of the panels and pipework, the system can be filled. When doing so, the thermal conditions and the particular features of the installation must be taken into account.

Rinsing and filling must not be carried out while the collectors are hot, as this could lead to scalding by heat transfer fluid vapour.

For this reason, the system may only be filled, commissioned and maintained by a suitably authorised technician. To prevent damage to the system, hydraulic testing should take place using the heat transfer fluid to be subsequently used.

Heat transfer fluid

In order to prevent frost and corrosion damage to the collectors and connectors, the system may only be filled with a high-quality heat transfer fluid (propylene glycol and water mix). If the recommended ready-mixed fluid is used, this provides adequate frost protection to approx. -24 °C.

Instructing the operator

The installer must instruct the system operator in the function, operation and required servicing intervals of the system.

The system operator must be handed the instructions for installation and use for safekeeping.

Safekeeping of the installation instructions

The instructions for installation and use should be handed over to the system operator. The operator is then responsible for their safekeeping so that they can be referred to in the future if necessary.

da Overdragelse (opstart)

Efter installation af solpanel og hydrauliske forbindelser af panel samt udført rør-arbejde til systemet, kan væske nu påfyldes.

Når anlægget fyldes skal der tages hensyn til termiske forhold (temp.) samt andre komponenter (unit) der indgår i installationen (pumpegruppe, vv.beholder mm.)

Gennemskyldning og påfyldning må ikke foretages medens panelet er varmt, da dette kan føre til skoldning fra damp fra den varmetransporterende væske. Derfor må systemet kun fyldes ved opstart og servicering af autoriseret teknisk personel. For at undgå skader på systemet, skal den hydrauliske test foretages med samme væske som efterfølgende anvendes i systemet.

Varmetransporterende væske

For at forhindre frost- og korrosions- skader i panelet og irørforbindelser, må systemet kun fyldes med høj-kvalitets væske (propylen glykol og vand). Hvis den anbefalede færdigblandede solfangervæske anvendes, forebygger dette en frostsbeskyttelse ned til ca. -24°C.

Instruktion til slutbruger

Installatøren skal instruere systemets operatør (bruger) i funktionen, betjeningen samt service og vedligeholdelse af anlægget. Brugeren skal have udleveret instruktion for installation og betjening (bruger-vejledning).

Ansvar for installationens instruktion

Instruktionen for installation og brug skal overrækkes til systemets operatør (bruger). Operatøren (brugeren) har herefter ansvaret for at opbevare instruktionen.

sv Överlämning (uppstart)

Följande installation av solfångare med rörledningar kan nu fyllas med frysskyddsvätska.

När anläggningen fylls skall hänsyn tas till termiska förhållanden (temperatur) samt andra komponenter som ingår i anläggningen (pumpgrupp, tank mm). Påfyllning och genomspolning får inte ske medan panelerna varma då detta kan leda till skällning om vätska kommer ur rörledningen. Av den anledningen bör anläggningen fyllas av auktoriserad installatör. För att undgå skador i solfångarkretsen skall provkörning göras med samma vätska som sedan kommer att användas för drift.

Frysskyddsvätska

För att förhindra frys och korrosions skador i anläggningen skall den endast fyllas med hög-kvalitets vätska (propylenglykol och vatten). Om den rekommenderade färdigblandade vätskan används förebygger den frysskador ned till ca -24°C.

Instruktion till användaren

Installatören skall instruera systemets användare om vilka funktioner som finns och om hur anläggningen skall skötas. Instruktioner och manualer om anläggningen skall överlämnas till användaren.

Ansvar för installationens instruktion

Användaren är ansvarig för instruktioner och manualer förvaras på ett säkert ställe så att dom är tillgängliga om nödvändigt i framtiden.



Sol & Energiteknik SE AB

Esbjörnarp 10

SE- 56192 Huskvarna

 : +46 (0) 36 - 51345

www.solenergiteknik.se